

DANIEL®  
**SPRING LOADED BACK  
PRESSURE VALVE**  
USER MANUAL

**SERIES 700 - MODEL V707**  
NPS 2 THROUGH 4 / CLASS 150-600



**DANIEL®**

OCTOBER 2022

## Signal words and symbols

Pay special attention to the following signal words, safety alert symbols and statements:



Safety alert symbol

This is a safety alert symbol. It is used to alert you to potential physical injury hazards. Obey all safety messages that follow this symbol to avoid possible injury or death.



### **DANGER**

Danger indicates a hazardous situation which, if not avoided, will result in death or serious injury.



### **WARNING**

Warning indicates a hazardous situation which, if not avoided, could result in death or serious injury.



### **CAUTION**

Caution indicates a hazardous situation which, if not avoided, could result in minor or moderate injury.

---

### **NOTICE**

Notice is used to address safety messages or practices not related to personal injury.

---

### **Important**

Important is a statement the user needs to know and consider.

---

### **Tip**

Tip provides information or suggestions for improved efficiency or best results.

---

### **Note**

Note is "general by-the-way" content not essential to the main flow of information.

---

**Important safety instructions**

Daniel Measurement and Control, Inc. (Daniel) designs, manufactures and tests products to function within specific conditions. Because these products are sophisticated technical instruments, it is important that the owner and operation personnel must strictly adhere both to the information printed on the product and to all instructions provided in this manual prior to installation, operation, and maintenance.

Daniel also urges you to integrate this manual into your training and safety program.

BE SURE ALL PERSONNEL READ AND FOLLOW THE INSTRUCTIONS IN THIS MANUAL AND ALL NOTICES AND PRODUCT WARNINGS.

 **WARNING**

Failure to follow the installation, operation or maintenance instructions for a Daniel product could lead to serious injury or death from explosion or exposure to dangerous substances.

To reduce the risk:

- Comply with all information on the product, in this manual, and in any local and national codes that apply to this product.
- Do not allow untrained personnel to work with this product.
- Use Daniel parts and work procedures specified in this manual.

**Product owners (Purchasers):**

- Use the correct product for the environment and pressures present. See technical data or product specifications for limitations. If you are unsure, discuss your needs with your Daniel representative.
- Inform and train all personnel in the proper installation, operation, and maintenance of this product.
- To ensure safe and proper performance, only informed and trained personnel should install, operate, repair and maintain this product.
- Verify that this is the correct instruction manual for your Daniel product. If this is not the correct documentation, contact Daniel at 1-713-827-6314. You may also download the correct manual from: <https://www.Daniel.com/en-us/automation/daniel>.
- Save this instruction manual for future reference.
- If you resell or transfer this product, it is your responsibility to forward this instruction manual along with the product to the new owner or transferee.
- ALWAYS READ AND FOLLOW THE INSTALLATION, OPERATIONS, MAINTENANCE AND TROUBLESHOOTING MANUAL(S) AND ALL PRODUCT WARNINGS AND INSTRUCTIONS.
- Do not use this equipment for any purpose other than its intended service. This may result in property damage and/or serious personal injury or death.

### **Product operation (Personnel):**

- To prevent personal injury, personnel must follow all instructions of this manual prior to and during operation of the product.
- Follow all warnings, cautions, and notices marked on, and supplied with, this product.
- Verify that this is the correct instruction manual for your Daniel product. If this is not the correct documentation, contact Daniel at 1-713-827-6314. You may also download the correct manual from: <https://www.Daniel.com/en-us/automation/daniel>.
- Read and understand all instructions and operating procedures for this product.
- If you do not understand an instruction, or do not feel comfortable following the instructions, contact your Daniel representative for clarification or assistance.
- Install this product as specified in the INSTALLATION section of this manual per applicable local and national codes.
- Follow all instructions during the installation, operation, and maintenance of this product.
- Ensure that all connections to pressure and electrical sources are secure prior to and during equipment operation.
- Use only replacement parts specified by Daniel. Unauthorized parts and procedures can affect this product's performance, safety, and invalidate the warranty. "Look-a-like" substitutions may result in deadly fire, explosion, release of toxic substances or improper operation.
- Save this instruction manual for future reference.

**Notice**

THE CONTENTS OF THIS PUBLICATION ARE PRESENTED FOR INFORMATIONAL PURPOSES ONLY, AND WHILE EVERY EFFORT HAS BEEN MADE TO ENSURE THEIR ACCURACY, THEY ARE NOT TO BE CONSTRUED AS WARRANTIES OR GUARANTEES, EXPRESSED OR IMPLIED, REGARDING THE PRODUCTS OR SERVICES DESCRIBED HEREIN OR THEIR USE OR APPLICABILITY. ALL SALES ARE GOVERNED BY DANIEL'S TERMS AND CONDITIONS, WHICH ARE AVAILABLE UPON REQUEST. WE RESERVE THE RIGHT TO MODIFY OR IMPROVE THE DESIGNS OR SPECIFICATIONS OF SUCH PRODUCTS AT ANY TIME.

DANIEL DOES NOT ASSUME RESPONSIBILITY FOR THE SELECTION, USE OR MAINTENANCE OF ANY PRODUCT. RESPONSIBILITY FOR PROPER SELECTION, USE AND MAINTENANCE OF ANY DANIEL PRODUCT REMAINS SOLELY WITH THE PURCHASER AND END-USER.

TO THE BEST OF DANIEL'S KNOWLEDGE THE INFORMATION HEREIN IS COMPLETE AND ACCURATE. DANIEL MAKES NO WARRANTIES, EXPRESSED OR IMPLIED, INCLUDING THE IMPLIED WARRANTIES OF MERCHANTABILITY AND FITNESS FOR A PARTICULAR PURPOSE WITH RESPECT TO THIS MANUAL AND, IN NO EVENT, SHALL DANIEL BE LIABLE FOR ANY INCIDENTAL, PUNITIVE, SPECIAL OR CONSEQUENTIAL DAMAGES INCLUDING, BUT NOT LIMITED TO, LOSS OF PRODUCTION, LOSS OF PROFITS, LOSS OF REVENUE OR USE AND COSTS INCURRED INCLUDING WITHOUT LIMITATION FOR CAPITAL, FUEL AND POWER, AND CLAIMS OF THIRD PARTIES.

PRODUCT NAMES USED HEREIN ARE FOR MANUFACTURER OR SUPPLIER IDENTIFICATION ONLY AND MAY BE TRADEMARKS/ REGISTERED TRADEMARKS OF THESE COMPANIES.

### Warranty and Limitations

1. **LIMITED WARRANTY:** Subject to the limitations contained in Section 2 herein, Daniel Measurement & Control, Inc. ("Daniel") warrants that the licensed firmware embodied in the Goods will execute the programming instructions provided by Daniel, and that the Goods manufactured by Daniel will be free from defects in materials or workmanship under normal use and care and Services will be performed by trained personnel using proper equipment and instrumentation for the particular Service provided. The foregoing warranties will apply until the expiration of the applicable warranty period. Goods are warranted for twelve (12) months from the date of initial installation or eighteen (18) months from the date of shipment by Daniel, whichever period expires first. Consumables and Services are warranted for a period of 90 days from the date of shipment or completion of the Services. Products purchased by Daniel from a third party for resale to Buyer ("Resale Products") shall carry only the warranty extended by the original manufacturer. Buyer agrees that Daniel has no liability for Resale Products beyond making a reasonable commercial effort to arrange for procurement and shipping of the Resale Products. If Buyer discovers any warranty defects and notifies Daniel thereof in writing during the applicable warranty period, Daniel shall, at its option, correct any errors that are found by Daniel in the firmware or Services or repair or replace F.O.B. point of manufacture that portion of the Goods or firmware found by Daniel to be defective, or refund the purchase price of the defective portion of the Goods/Services. All replacements or repairs necessitated by inadequate maintenance, normal wear and usage, unsuitable power sources or environmental conditions, accident, misuse, improper installation, modification, repair, use of unauthorized replacement parts, storage or handling, or any other cause not the fault of Daniel are not covered by this limited warranty, and shall be at Buyer's expense. Daniel shall not be obligated to pay any costs or charges incurred by Buyer or any other party except as may be agreed upon in writing in advance by Daniel. All costs of dismantling, reinstallation and freight and the time and expenses of Daniel's personnel and representatives for site travel and diagnosis under this warranty clause shall be borne by Buyer unless accepted in writing by Daniel. Goods repaired and parts replaced by Daniel during the warranty period shall be in warranty for the remainder of the original warranty period or ninety (90) days, whichever is longer. This limited warranty is the only warranty made by Daniel and can be amended only in a writing signed by Daniel. THE WARRANTIES AND REMEDIES SET FORTH ABOVE ARE EXCLUSIVE. THERE ARE NO REPRESENTATIONS OR WARRANTIES OF ANY KIND, EXPRESS OR IMPLIED, AS TO MERCHANTABILITY, FITNESS FOR PARTICULAR PURPOSE OR ANY OTHER MATTER WITH RESPECT TO ANY OF THE GOODS OR SERVICES. Buyer acknowledges and agrees that corrosion or erosion of materials is not covered by this warranty.

2. **LIMITATION OF REMEDY AND LIABILITY:** Daniel shall not be liable for damages caused by delay in performance. The remedies of Buyer set forth in this agreement are exclusive. In no event, regardless of the form of the claim or cause of action (whether based in contract, infringement, negligence, strict liability, other tort or otherwise), shall Daniel's liability to Buyer and/or its customers exceed the price to Buyer of the specific goods manufactured or services provided by Daniel giving rise to the claim or cause of action. Buyer agrees that in no event shall Daniel's liability to Buyer and/or its customers extend to include incidental, consequential or punitive damages. The term "consequential damages" shall include, but not be limited to, loss of anticipated profits, revenue or use and costs incurred including without limitation for capital, fuel and power, and claims of Buyer's customers.

# Contents

## Part I Plan

<b>Chapter 1</b>	<b>Introduction.....</b>	<b>13</b>
	1.1 Purpose of this manual.....	13
	1.2 Description of the 707 Backpressure Control Valves.....	13
<b>Chapter 2</b>	<b>Operating conditions and specifications.....</b>	<b>19</b>
	2.1 Operating conditions for the 707 control valve.....	19
	2.2 Specifications for the control valve.....	22
<b>Chapter 3</b>	<b>Control valve handling.....</b>	<b>27</b>
	3.1 Receive the control valve.....	27
	3.2 Store the control valve.....	27
	3.3 Lifting conditions.....	28
	3.4 Lifting requirements for personnel.....	29
	3.5 Configure the control valve.....	31

## Part II Install

<b>Chapter 4</b>	<b>Installation prerequisites.....</b>	<b>37</b>
	4.1 Pre-start checks.....	37
	4.2 Torque information.....	37
	4.3 Torque values (flanges).....	38
	4.4 Torque pattern sequences.....	38
	4.5 Tools required for control valve installation.....	38
<b>Chapter 5</b>	<b>Installation procedure.....</b>	<b>39</b>
	5.1 External components assembly.....	39
<b>Chapter 6</b>	<b>Testing the product.....</b>	<b>41</b>
	6.1 Commission the control valve.....	41

## Part III Operate

<b>Chapter 7</b>	<b>Operation parameters.....</b>	<b>45</b>
	7.1 Control valve normal operation.....	45
	7.2 Operation overview.....	45

## Part IV Maintain

<b>Chapter 8</b>	<b>Planned maintenance.....</b>	<b>49</b>
	8.1 Maintenance considerations.....	49

- 8.2 Tools required for mechanical components..... 49
- 8.3 Disassemble/Assemble the control valve..... 49
- 8.4 Mechanical assembly..... 51
- 8.5 Planned maintenance tasks..... 53
- Chapter 9 Corrective maintenance..... 55**
  - 9.1 Control valve troubleshooting..... 55
  - 9.2 Verify the return to operational condition..... 55
- Chapter 10 Spare parts..... 57**
  - 10.1 Recommended spare parts..... 57
- Chapter 11 Decommission..... 59**
  - 11.1 Shut down the control valve..... 59
  - 11.2 Shipment of the control valve..... 59



# Part I Plan

# 1 Introduction

## 1.1 Purpose of this manual

This manual provides guidance to owners and personnel in the installation, operation and maintenance of the *Daniel™ Series 707 Control Valve manual, DAN-20064957*. It is imperative that product owners and operation personnel read and follow the information contained in this manual to ensure that the control valve is installed correctly and is operating according to the design certifications and safety considerations.

## 1.2 Description of the 707 Backpressure Control Valves

### 1.2.1 General features of the 707 control valve

The Daniel™ 707 Control Valve is a spring actuated pilotless valve. It uses the compression force of pre-loaded heavy springs installed in the valve body to counter the developing pump pressure at the upstream of the valve.

The valve comes configured with a check valve to prevent reverse flow and an adjustment screw mechanism to adjust the spring pre-load.

The Daniel 707 Control Valves have the following characteristics:

- Modular construction: All internal parts including seat ring can be removed with the cylinder assembly without disturbing line connections.
- Pilotless
- No diaphragms
- 45° body design assures high capacity
- Positive shut-off
- O-ring plus metal-to-metal seat

### 1.2.2 Control valve applications

The 707 valve is designed primarily to maintain back pressure at the upstream of the valve. It does not require a pilot control loop to operate and as such is better suited for high viscosity and crude oil applications.

### 1.2.3 Operations overview of the 707 control valve

The Daniel 707 spring actuated control valve uses the force generated by the compression of heavy springs installed on the spring side to the piston to counter the pressure on the

bottom side of the piston. The pressure at the bottom side of the piston must exceed the spring force to unseat the piston and open the valve.

An adjustment mechanism provides a means to adjust the spring load in the back of the piston, which adjusts the valve opening pressure within the spring's pressure range or set point range. The 707 springs are a nested design; this allows two springs to be combine for 3<sup>rd</sup> set point which is an extension of the first two. The designed set point ranges for the 707 springs are as follow.

707 Springs	Set-point range (Psig)
Light	5 to 40
Medium	30 to 80
Combined	30 to 120

Once the operating pressure or set point is reached, the valves opens and begins to flow. The 707 has a balanced piston design, which means that the spring force on the spring side of the piston must be equal or greater than the pressure at the bottom side for the valve to remain closed.

**Closed position**

Figure 1-1 illustrates a closed valve. The pressure at the bottom side of the piston P1 is less than the spring force F1 plus the check line pressure the P2. The piston is kept seated and the valve remains closed.

**Figure 1-1: Valve in closed position**

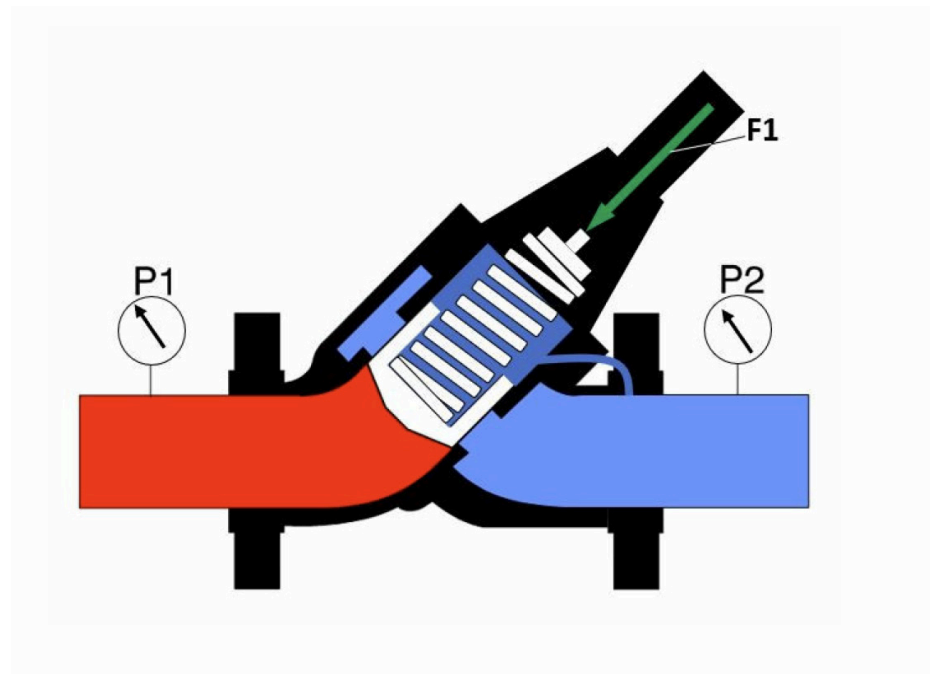

**Open valve - No control**

Figure 1-2 shows the valve in the open position. The pressure at the bottom of the piston **P1** is greater than the force of the spring **F1** plus the check valve pressure **P2**.

**Figure 1-2: Valve in open position**

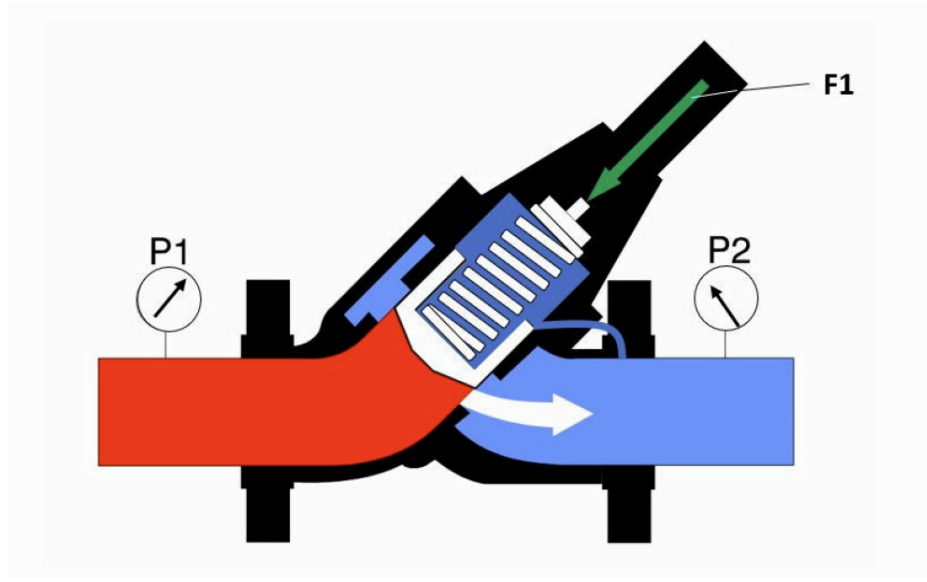

## 1.2.4 Part list for the 707 control valves

Figure 1-3: Part identification for an NPS 2-4 inch Control Valve

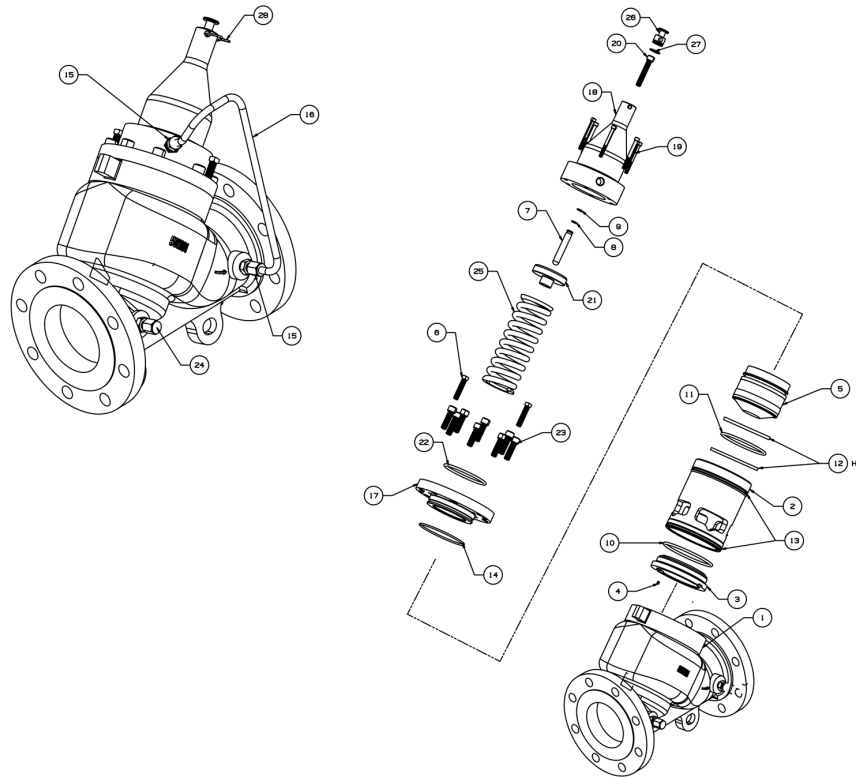

Table 1-1: Part description for a 707 Control Valve

Item number	Description	Quantity
1	Valve body	1
2	Cylinder	1
3	Piston Retainer	1
4	Retainer Set Screw	1
5	Piston	1
6	Jack Screw	2
7	Plunger	1
8	Plunger O-ring	1
9	Plunger Back up ring	1
10	Valve Seat O-ring	1

**Table 1-1: Part description for a 707 Control Valve (continued)**

Item number	Description	Quantity
11	Piston O-ring	1
12	Piston Backup Rings (High Pressure)	2
13	Cylinder O-ring	2
14	Cylinder Head O-ring	1
15	Connector, 3/8 NPT X 3/8" Tube	2
16	Stainless Steel Tubing	1
17	Cylinder Head	1
18	SPRING COVER	1
19	Spring Cover Bolts 1/4 -20	Varies
20	Adjustment Scew 3/8 -24	1
21	Spring Guide	1
22	Spring Cover O-ring	1
23	Cylinder head bolts	Varies
24	PLUG PIPE SQR HD 3/8 NPT CS ZP	1
25	Valve Spring	Varies
26	Locking Cap	2
27	Loacking Cap O-ring	1
28	Twist wire/Zip tie	1

## 2 Operating conditions and specifications

### 2.1 Operating conditions for the 707 control valve

Table 2-1: Operating conditions for the control valve

Condition type	Description
Fluid phase	Liquid
Process temperature	-29 °C to 66 °C (-20 °F to 150 °F)
Fluid velocity	Operational recommended flow velocity up to 30 ft/sec, beyond this point will result in a high pressure drop and increased wear.
Fluid(s) controlled	<ul style="list-style-type: none"> <li>• Low/Medium viscosity crude oils and condensates</li> <li>• Refined products and intermediates (ie: gasoline, diesel, kerosene, light fuel oils, jet fuel, LPG, butanes, naphtha, alkylate, reformat, straight run gasoline, cat-cracked gasoline)</li> <li>• Petrochemicals (ie: benzene, toluene, xylenes, cumene, olefins, pyrolysis gasoline)</li> <li>• Natural gas liquids</li> </ul>
Viscosity limits	Maximum valve viscosity is 8800 Cst
Differential pressure	The maximum allowable differential pressure across a control valve is 6894 kPa (1,000 psi). Consult factory for location of first shut down valve.
Sizes (NPS)	2, 3, 4
Pressure class (ANSI)	150, 300, 600
Maximum safe working temperature range	<ul style="list-style-type: none"> <li>• -26 °C to 204 °C (15 °F to 400 °F)</li> <li>• Using Viton® O-rings</li> <li>• Consult the factory for other safe working temperatures</li> </ul>
Maximum safe working pressure	Flange connections/Ratings (ANSI) for valve sizes 2"- 4": <ul style="list-style-type: none"> <li>• Class 150 MWP at 100 °F: 285 psi</li> <li>• Class 300 MWP at 100 °F: 740 psi</li> <li>• Class 600 MWP at 100 °F: 1480 psi</li> </ul> * MWP: Maximum Working Pressure

**Table 2-1: Operating conditions for the control valve (continued)**

Condition type	Description
Materials of construction	Main valve body: Steel, ASTM-A352 Gr. LCC Main valve cylinder: <ul style="list-style-type: none"> <li>• NPS 2-4: 17-4 PH</li> </ul> Main valve piston: Stainless steel (standard) Seat ring: <ul style="list-style-type: none"> <li>• Class 150 and 300:                             <ul style="list-style-type: none"> <li>— NPS 2-4: Stainless steel</li> </ul> </li> <li>• Class 600: Stainless steel</li> </ul> O-Rings: <ul style="list-style-type: none"> <li>• Standard: Viton®</li> <li>• For other material contact the factory</li> </ul> External hook up: <ul style="list-style-type: none"> <li>• Class 150 and 300:                             <ul style="list-style-type: none"> <li>— NPS 2-4: Carbon steel/Stainless steel 10 mm (0.375")</li> </ul> </li> <li>• Class 600:                             <ul style="list-style-type: none"> <li>— NPS 2-4: Stainless steel 13 mm (0.5")</li> </ul> </li> </ul> Other internal parts: Stainless steel

### 2.1.1 Design considerations

Some conditions to consider:

- Service operating pressure
- Service testing pressures
- Service process temperature and ambient site temperatures
- Chemical composition and toxicity of fluid in operating conditions
- Traffic, wind and earthquake at loading site
- Adverse force or stress caused by inadequate supports, attachments, piping, etc.
- Corrosion, erosion, fatigue, etc.
- Decomposition of unstable fluids in operating and test conditions
- Possible damage from external fire
- Mass fluid in process and test conditions

 **WARNING**

**FUNCTIONAL AND ENVIRONMENTAL HAZARD**

Evaluate the functional and environmental conditions prior to installing a control valve. Install the control valve in a well-designed piping system.

Failure to comply may result in death or serious injury from pipe failure.



## 2.1.2 Environmental conditions



**WARNING**  
EQUIPMENT HAZARD

Never use this equipment for any purpose other than its intended use.

Failure to comply may result in death, serious personal injury and/or property damage.

**Table 2-2: Environmental conditions**

Parameter type	Description
Severe service conditions	Ensure that piping or other attachments connected to the valve are not under stress. The design of the control valve has not been assessed for the effects of wind, earthquake loading and severe weather conditions.
Additional severe service conditions	The valves are designed to be used on liquid applications for crude oil and refined products.
Corrosive service	Select the material compatible with the specific processes and atmospheric environments. Implement a periodic inspection and maintenance program to ensure that pressure retaining components are free from corrosion and erosion.  The valve is not designed with corrosion allowance. Inspect the valve's metal parts periodically for corrosion and erosion, and inspect the seals and O-rings for wear and chemical deterioration.
Low and freezing temperatures	Low specific gravities or high viscosities reduce the flow range of the valve. Refer to Operations overview of the 707 control valve for more information.
Populated areas	For new installations, follow the guidelines for Class Locations found in the U.S. DOT, CRF Title 49: Part 192.5
Closed, poorly ventilated areas	Install the control valve in a well ventilated area, not less than one meter (approximately three feet) from source of ignition or source of heat which might damage the unit.
Elevation	No limit
Humidity	No limit
Proximity to open flame	Provide fire prevention measures and equipment per local regulations.
Proximity to vehicular traffic	The design of the control valve has not been assessed for the effects of traffic.

## 2.2 Specifications for the control valve

### 2.2.1 Interface requirements

 **WARNING**

**EXCEEDING REQUIREMENTS HAZARD**

Control valve requirements are defined to ensure safe equipment operation. Do not exceed published specifications.

Failure to comply may result in death, serious injury and/or damage to the equipment.

**Table 2-3: Interface requirements**

Requirements	Description
Hydraulic lines	External hook up: <ul style="list-style-type: none"> <li>• ANSI class 150 and 300:                             <ul style="list-style-type: none"> <li>– NPS 2-4: Carbon steel/Stainless steel 10 mm (0.375")</li> </ul> </li> <li>• ANSI class 600:                             <ul style="list-style-type: none"> <li>– NPS 2-4: Stainless steel 13 mm (0.5")</li> </ul> </li> </ul>
Flange type	The mechanical connections for a Series 700 control valve NPS 2 to 4 are standard class 150, 300 and 600 ANSI R.F. flanges, which are available only in carbon steel. For maximum working pressures at intermediate temperatures refer to ANSI B16.5.

 **WARNING**

**FLANGE SIZE HAZARD**

Customers must choose the appropriate size material of the flange for their piping requirements.

Choosing an incorrect flange may cause a pressure leak, resulting in death or serious injury.

### 2.2.2 Requirements and limitations for installation

**NOTICE**

Comply with local government regulations and company requirements.

See Figure 2-1 for flow direction.

**NOTICE**

Flush lines to remove welding bead, pipe scale, etc.

**NOTICE**

Install the valve in a horizontal line with the cylinder head at the top.

Figure 2-1: Valve orientation

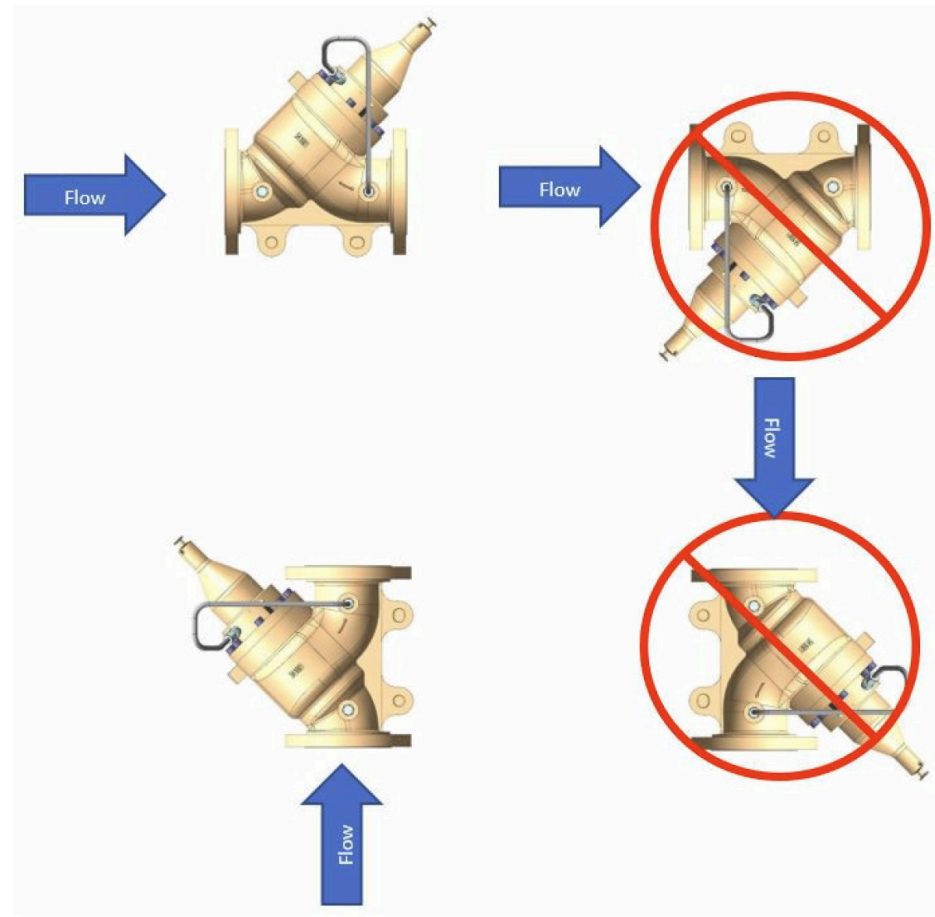

**⚠ WARNING**  
 EQUIPMENT HAZARD  
 Never use this equipment for any purpose other than its intended use.  
 Failure to comply may result in death, serious personal injury and/or property damage.

### 2.2.3 Minimum clearances for installation, operation and maintenance

Figure 2-2: Dimensions of the control valve

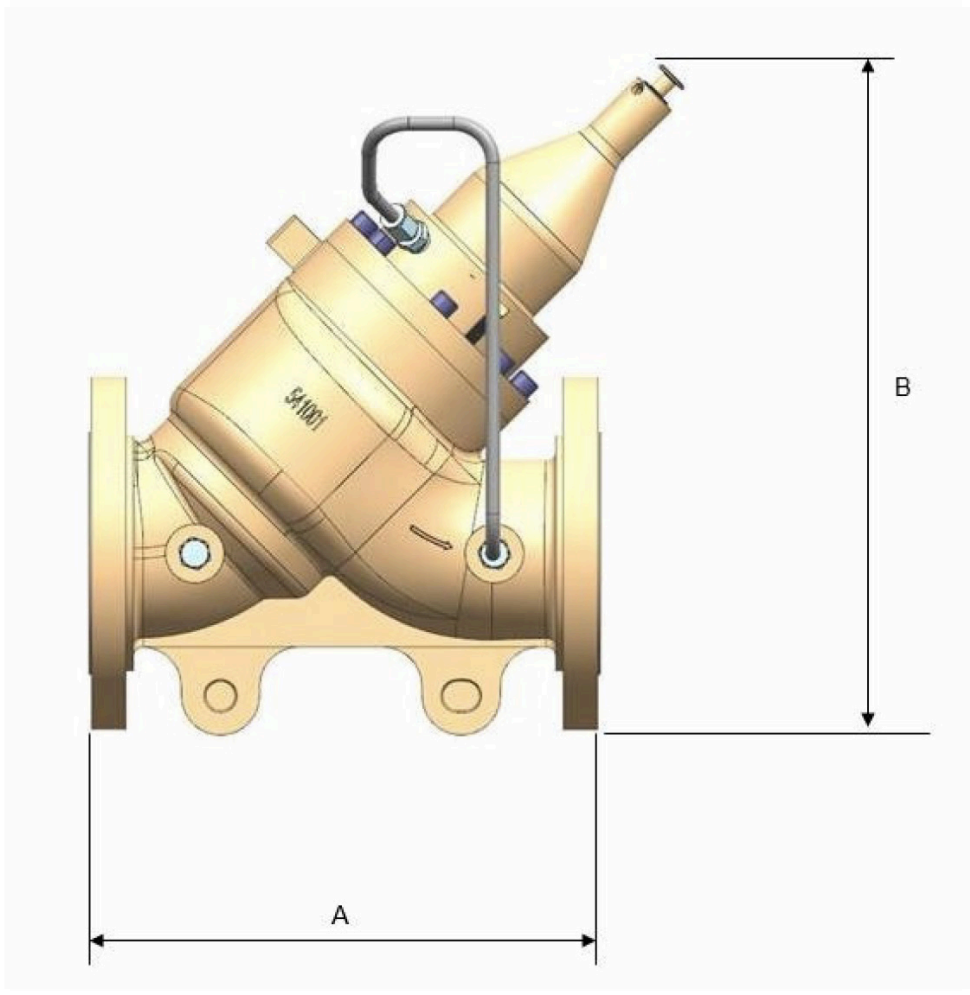

Table 2-4: Approximate weight table for the 707 control valve

Line size		ANSI 150-300		ANSI 600	
DN	Inches	lbs	Kg	lbs	Kg
50	2	60	27	100	45
80	3	105	48	150	68
100	4	140	63	205	93

**Table 2-5: Dimensions for the 707 Backpressure Control Valve**

Valve Size (in)	A						B			
	ANSI 150		ANSI 300		ANSI 600		ANSI 150-300		ANSI 600	
	in	mm	in	mm	in	mm	in	mm	in	mm
2	10-1/4	260	10-1/2	267	11-1/2	292	12-7/8	327	14-3/8	365
3	11	279	13-1/8	333	14	356	14-3/4	375	16-1/4	413
4	13	330	14-1/2	368	17	432	16-3/8	416	18	457

## 3 Control valve handling

### 3.1 Receive the control valve

 **WARNING**

**EQUIPMENT HANDLING AND OPERATING HAZARD**

Wear personal protective equipment appropriate to the situation when working with the control valve. Adhere to all safety standards and best practices for operating the equipment.

Failure to comply may result in death or serious injury.

#### 3.1.1 Unpack and inspect the control valve

Check the control valve when it is received at the customer facility.

**Procedure**

1. Remove the control valve from the shipping container.
2. Inspect the control valve for damage.
3. See Installation procedure.

### 3.2 Store the control valve

#### 3.2.1 Rust inhibitor

Apply light oil or rust inhibitor on surfaces that are in contact with the environment.

#### 3.2.2 Pack the control valve

**Procedure**

1. Use stretch wrap (not adhesive) to attach the correct size flange cover to the valve end flanges. This protects the unpainted surfaces of the flange sealing.
2. A flush contact between the flange cover and the flange sealing face is important.

### 3.2.3 Storage conditions

Store the control valve in a safe area to avoid damage.

 **WARNING**  
CRUSHING HAZARD

During installation or removal of a control valve, always place the unit on a stable platform or surface that supports its assembled weight.

Failure to comply may allow the control valve to roll, resulting in death, serious injury or equipment damage.

**Table 3-1: Control valve storage conditions**

Parameter type	Description
Storage environment conditions	For long term storage, it is recommended that the complete control valve assembly be stored under cover in a controlled environmental atmosphere in the original packaging. The storage temperature limits are: 20 °C to 60 °C (68 °F to 140 °F) .
Shelf life for elastomers	Inspect O-rings for wear or damage during disassembly of the cover and right before assembling the unit. Replace damaged elastomer. Viton® has an unlimited shelf life.
Inspect stored equipment	Examine the internal surfaces and flange faces of the control valve at least once every three months. Repack the control valve as originally received.
Labels and nameplates	Do not remove nameplates or labels. Doing so will void the control valve warranty.
Stacking conditions	When stacking equipment, follow all the safety standards taking into account the type of box used, the maximum height of the equipment, the maximum number of boxes stacked, etc.

### 3.3 Lifting conditions

 **WARNING**  
CRUSHING HAZARD

During installation or removal of a control valve, always place the unit on a stable platform or surface that supports its assembled weight.

Failure to comply may allow the control valve to roll, resulting in death, serious injury or equipment damage.

 **WARNING**  
LIFTING HAZARD

The lifting instructions are for installation and removal of a Daniel control valve only and do not address lifting the control valve while it is attached or bolted to piping.

Failure to follow these instructions may result in death, serious injury or equipment damage.

**⚠ CAUTION**

**FORKLIFT HAZARD**

Do not insert the forks of a forklift into the bore when moving the control valve. Inserting the forks may cause the meter to become unstable, resulting in serious injury or equipment damage.

**Table 3-2: Lifting and installation conditions**

Conditions	Description
Ventilation and lightning	Install the control valve in a well lit and ventilated location, not less than one meter (approximately three feet) from source of ignition or source of heat which might damage the unit.
Work area clearances and installation height restrictions	Refer to Minimum clearances for installation, operation and maintenance for clearances.
Surface considerations	Stable surface.
Soil/floor loadings and product/piping support	Follow local procedures that meet the standards for soil/floor loading and product/piping support.

## 3.4 Lifting requirements for personnel

### 3.4.1 Safety precautions using appropriately rated lifting slings

**⚠ WARNING**

**LIFTING HAZARD**

The lifting instructions are for installation and removal of a Daniel control valve only and do not address lifting the control valve while it is attached or bolted to piping.

Failure to follow these instructions may result in death, serious injury or equipment damage.

- Only personnel properly trained in the safe practices of rigging and lifting should lift valves.
- Prior to use, visually inspect the slings for any signs of abrasion or other damage. Refer to the sling manufacturer for inspection procedures specific to the sling you are using.
- Never attempt to lift the valve by wrapping slings around the visual indicator, position indicator pilots, needle valves, accessories or tubing.
- Never attempt to lift the valve using only one sling around the valve. Always use two slings wrapped around each end of the body as shown below. Use a choker style sling with a spreader bar.



Figure 3-1: Correct sling attachment

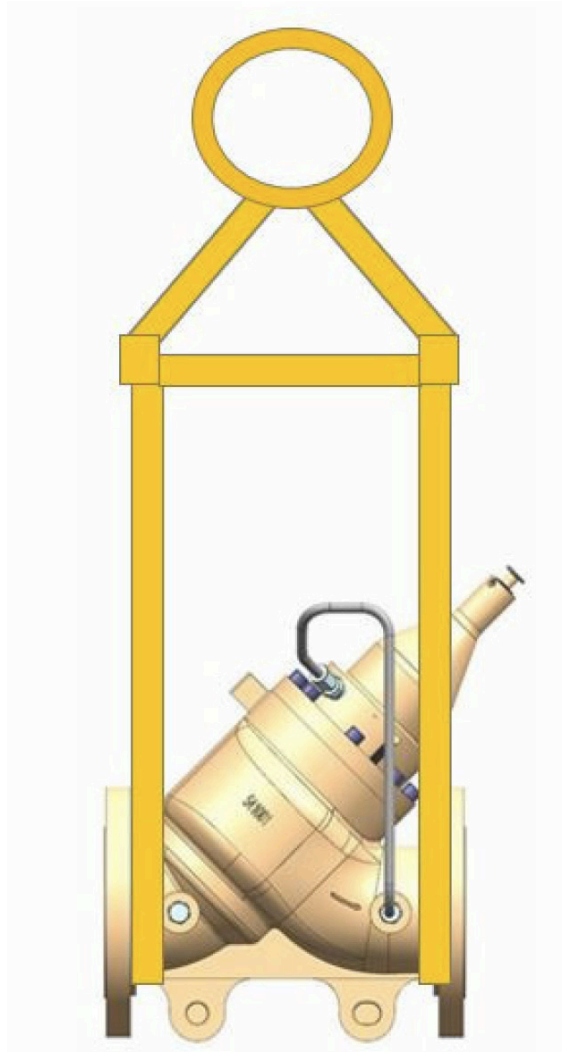

- Only use slings with ratings that exceed the weight to be lifted. Reference all safety standards for safety factors that must be included when calculating the load rating.

**! CAUTION**

**SLING HAZARD**

Never allow the slings to come in contact with the visual indicator, position indicator, pilots, needle valves, accessories or tubing. Use a spreader bar on the sling to prevent contact.

Failure to comply may cause equipment damage.

- Never apply shock loads to the valve. Always lift the control valve gradually. If shock loading occurs, inspect the slings per manufacturer's procedures before reuse.

 **WARNING**

**EQUIPMENT HANDLING AND OPERATING HAZARD**

Wear personal protective equipment appropriate to the situation when working with the control valve. Adhere to all safety standards and best practices for operating the equipment.

Failure to comply may result in death or serious injury.

## 3.5 Configure the control valve

The factory configures Daniel control valve internal components. Inspect the internal components before installation.

### 3.5.1 Orientation and position of the control valve

#### Flow direction

---

**NOTICE**

Comply with local government regulations and company requirements.

---

**NOTICE**

Flush lines to remove welding bead, pipe scale, etc.

---

**NOTICE**

Install the valve in a horizontal line with the cylinder head at the top.

---

Figure 3-2: Control valve flow direction

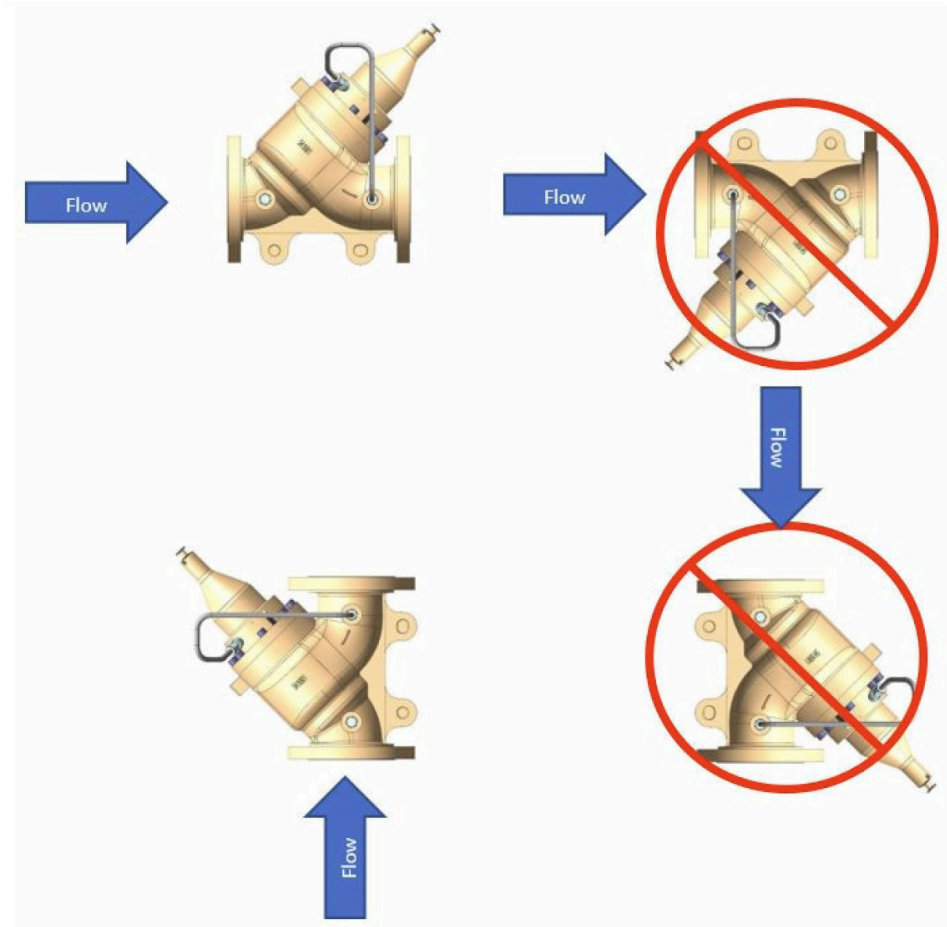

**! WARNING**

**EQUIPMENT HAZARD**

Never use this equipment for any purpose other than its intended use.

Failure to comply may result in death, serious personal injury and/or property damage.

### 3.5.2

## Piping recommendations

**NOTICE**

When installing the control valve, ensure that the bolts conform to the requirements of ASME B16.5 paragraph 5.3 and to the material requirements of ASME B16.5 Table 1B. Gaskets must conform to the requirements of ASME B16.20.

The design of the control valve has not been assessed for the effects of traffic, wind or earthquake loading.

---

**Important**

Ensure that piping or other attachments connected to the control valve are not under stress.

---

**Important**

Provide fire prevention measures and equipment per local regulations.

---

# Part II

# Install

## 4 Installation prerequisites

### 4.1 Pre-start checks

Ensure that the pipeline is completely free of all foreign material before installing the valve. The design of the control valve has not been assessed for the effects of traffic, wind or earthquake loading. Provide fire prevention measures and equipment per local regulations.

### 4.2 Torque information

---

**NOTICE**

When installing the control valve, ensure that the bolts conform to the requirements of ASME B16.5 paragraph 5.3 and to the material requirements of ASME B16.5 Table 1B. Gaskets must conform to the requirements of ASME B16.20.

---

**Tightening procedure:**

1. Lubricate the nuts and bolts.
  2. Hand-tighten until the nuts and bolts are snug against the flanges.
  3. Use the minimum pressure setting on an air wrench.
  4. Use the correct tightening sequence for the bolt flanges.
  5. Follow your company's internal flange installation procedures.
- 

**Important**

Ensure that piping or other attachments connected to the control valve are not under stress.

---

**Important**

Provide fire prevention measures and equipment per local regulations.

---

**Flanges with 4 and 8 bolts**

- First round - 30% of final torque (flange sequential order)
- Second round- 60% of final torque (flange sequential order)
- Third round - 100% of final torque (flange sequential order)
- One final time - clockwise or counter clockwise sequentially around the flange

## 4.3 Torque values (flanges)

Table 4-1: Reference torque values for Daniel Control Valve (ft-lb) flange connections

Nominal pipe size (NPS)	ANSI class 150	ANSI class 300	ANSI class 600
2	90	90	90
3	90	160	160
4	90	160	250

## 4.4 Torque pattern sequences

Table 4-2: Cross-pattern tightening sequence when using single tool

Nominal pipe size (NPS)	ANSI class 150	ANSI class 300	ANSI class 600
2	1-3-2-4	1-5-3-7 2-6-4-8	1-5-3-7 2-6-4-8
3	1-3-2-4	1-5-3-7 2-6-4-8	1-5-3-7 2-6-4-8
4	1-5-3-7 2-6-4-8	1-5-3-7 2-6-4-8	1-5-3-7 2-6-4-8

The position of the number 1 screw determines the position of the clockwise rotation of the subsequent screws.

## 4.5 Tools required for control valve installation

### Flange installation tools

Follow all best practice procedures when installing or removing flanges.

### Control valve components

The control valve does not have pre-installation requirements. If installation is required for maintenance purposes, use the following tools:

- Socket wrench
- Adjustable wrench
- T-handle or extended Allen wrench
- Arbor press (may be needed for 4- and 6-inch valves)
- Retaining ring pliers

# 5 Installation procedure

## 5.1 External components assembly

Install the external components (e.g., flanges) onto the pipeline.

The control valve is assembled at the factory. The components do not need to be uninstalled or reinstalled unless maintenance is required.

 **CAUTION**

**SURFACE TEMPERATURE HAZARD**

The control valve body and piping may be extremely hot or cold.

Wear personal protective equipment appropriate to the situation when working with the control valve. Adhere to your company's safety standards and practices.

Failure to comply may cause serious injury.

### 5.1.1 Fasteners

The property class of the fastener is in accordance with ASME B16.5.

**Stud bolt and nut types**

All fasteners (nuts and studs) used in assembling Daniel control valves are made of one of the materials listed in the table below.

**Table 5-1: Bolt material selection**

Bolt material selection	Description
ASTM SA 193 Grade B7 <63.5 mm (<2.5 in.)	High strength low alloy steel
ASTM SA 193 Grade B7M <63.5 mm (<2.5 in.)	Controlled strength low alloy steel
ASTM SA 320 Grade L7 <63.5 mm (<2.5 in.)	High strength low alloy low temperature steel
ASTM SA 320 Grade L7M <63.5 mm (<2.5 in.)	Controlled hardness low temperature steel
ASTM SA 449 <25.4 mm (<1.0 in.)	Quenched and tempered steel
ASTM SA 453 Grade 660	High temperature stainless steel

**Selection of stud bolts and nuts**

- Select all fasteners (nuts and studs) used in a hydrostatic test according to the flange size and class listed in ASME B16.5.
- Use the shortest stud bolt that permits full engagement of the thread through the nut by hand-tightening.
- Use only clean, rust-free nuts and stud bolts.

**Note**

Ensure that once the nut is tightened two threads outside the nut are exposed. The only exception is when a flange requires hydraulic bolt tensioning. The manufacturer of the



hydraulic bolt tensioning equipment will specify number of exposed threads outside the nut.

---

- Do not use damaged or worn stud bolts or nuts.
- Do not use nuts or stud bolts that do not fit together correctly.
- Do not use nuts or stud bolts without grade or type identification.
- Do not mix nuts or stud bolts of different coatings. Different nut and stud bolt coatings require different torques to achieve the same bolt tension.
- Do not assemble nuts with the identification hard stamp against the back face of the flange

#### **Stud bolt and nut storage**

Remove each nut and bolt as a pair. Thread the matching nut back onto the bolt. Stack them in a fashion that will not cause thread damage.

#### **Reuse of stud bolts and nuts**

The reuse of threaded fasteners is permitted on Daniel control valves under the following conditions:

- Fasteners are clean, free of corrosion, paint, thread damage, cracks, teeth marks (caused by wrenches) or other signs of damage.
- Fasteners are not tightened to or beyond their yield strength.
- Fasteners have not lost their coating.

Compare the threads of a used stud bolt with the thread of a new stud bolt. Finger-tighten the nut over the entire thread length of the bolt.

## 6 Testing the product

### 6.1 Commission the control valve

After installation, commission the control valve to ensure that the equipment is working properly.

#### Procedure

1. Inspect all bolts used to secure the control valve in-line to ensure that proper mounting procedures have been followed and that flange connections are leak-free.
2. Evaluate the system setup to ensure that all components are in the correct operating sequence.
3. Evaluate the system setup to ensure that all components are in the correct sequence for accurate product measurement. Some components are isolation valves, strainers, flow straighteners, turbine meters, downstream sections, etc.

# Part III

## Operate

## 7 Operation parameters

### 7.1 Control valve normal operation

The Daniel 707 control valves are pressure balanced, single-seated piston operated with 45° body construction. The valves are spring actuated and use pre-loaded spring force to counter the flowing stream.

Unique design features and unit-built construction ensures positive leak-proof performance. In addition, the basic valves body and internals are the same throughout the line, simplifying spare parts inventory and reducing costs.

### 7.2 Operation overview

The 707 Control Valve relies on spring pre-loads at the back of the piston to inlet flow.

When pressure on bottom side of the piston exceeds the spring pre-loaded force on the spring side of the piston, the valve opens and begins to flow. As pressure continue to increase the valve continues to open as more flow is induced across it.

 **CAUTION**

**EQUIPMENT DAMAGE**

Read the entire recommended procedure for all installation operations and maintenance procedures before attempting to install or disassemble the valve. Disassembly of this cylinder assembly is different from previous Daniel Control Valves and requires strict adherence to the procedures outlined in this manual.

Failure to read and comply with these procedures could result in damage to the equipment and compromise in the integrity of the operation.

# Part IV

## Maintain

## 8 Planned maintenance

### 8.1 Maintenance considerations

Read and understand all instructions and operating procedures before performing maintenance procedure, internal component inspection, or field requirement changes.

To ensure safe and accurate performance, only informed and trained personnel should install, operate, repair and maintain this product.

Follow the recommendations below before servicing the control valve:

1. Label all parts or place parts in labeled containers during disassembly.
2. Do not use metal clamping devices in direct contact with any control valve part or surface.

### 8.2 Tools required for mechanical components

#### Flange installation tools

Follow all best practice procedures when installing or removing flanges.

#### Control valve components

The control valve does not have pre-installation requirements. If installation is required for maintenance purposes, use the following tools:

- Socket wrench
- Adjustable wrench
- T-handle or extended Allen wrench
- Arbor press (may be needed for 4- valves)
- Retaining ring pliers

### 8.3 Disassemble/Assemble the control valve

Before removing the control valve from the system, the following precautions must be taken:

The meter must be cleaned completely inside the housing components and stored/shipped as it was received.

1. Label all parts or place parts in labeled containers during disassembly.
2. Do not use metal clamping devices in direct contact with any control valve part or surface.

The control valve must be cleaned completely inside the housing components and stored/shipped as it was received. Refer to Storage Preparations for cleaning instructions.

After the meter is shut down, refer to Disassembly for the detailed disassembly procedure.

After the previous steps have taken place, assemble the control valve per the instructions in Mechanical assembly.

### 8.3.1 Cylinder disassembly

#### Procedure

1. Remove the nuts that secure the cylinder head to the valve body.
2. Alternately tighten the jack-out screws until the cylinder assembly is free to be lifted out of the valve body.
3. Lift the cylinder assembly by the cylinder head. Remove it from the valve body and set it in a vertical position with the cylinder head on top.
4. Before removing the spring cover screws, place the cylinder assembly in an arbor press to immobilize the spring cover on top of the cylinder head. This is to prevent sudden spring pressure from being released and causing injury or damage.



#### **CAUTION**

##### **SPRING PRESSURE HAZARD**

Follow the instructions in Step 4.

Failure to comply may cause release of spring pressure, resulting in serious injury or equipment damage.

5. Use an Allen wrench to remove the screws that secure the spring cover to the cylinder, and then gradually release the arbor press to remove the spring cover from the cylinder head.
6. Remove the valve spring from the cylinder.
7. With the cylinder in a vertical position (ports located on the top part of the cylinder), place the piston, nose end up, into the recess between the cylinder and the seat ring. Use an arbor press to push the piston into the cylinder, thus freeing the seat ring from the cylinder.

Figure 8-1: Using the piston to remove the seat ring from the 150/300 lb cylinder

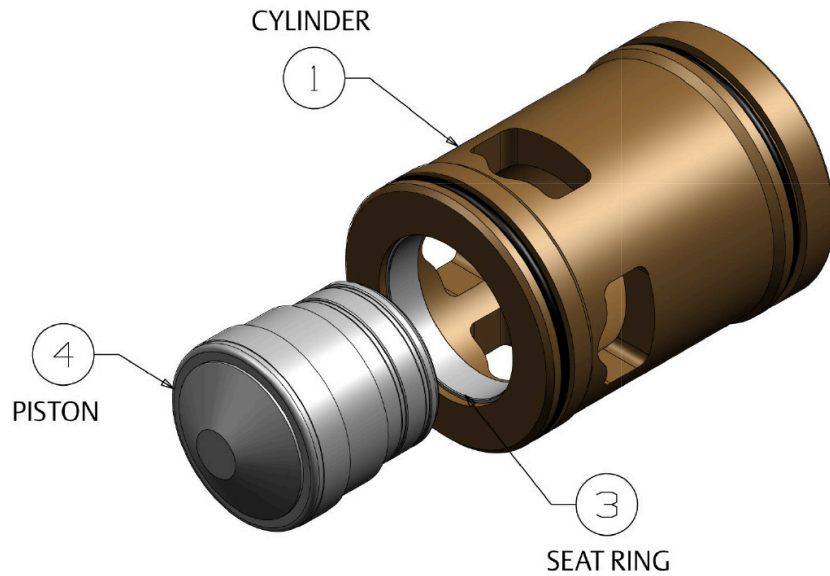

8. Turn the cylinder over with the ports on top when removing the high pressure seat ring. Remove the set screw from the seat ring. Turn the seat ring counterclockwise to remove the seat ring and then remove the O-ring from the cylinder.

## 8.4 Mechanical assembly

### 8.4.1 Valve torque specifications

Table 8-1: Valve cylinder head to body (stud-nut) torque specifications

Valve size (in)	Flange rating (lbs)	Num. bolts	Min. torque (lbs/ft)
2	150	6	6
	300	6	15
	600	6	67
3	150	6	15
	300	6	40
	600	8	49
4	150	8	13
	300	8	35
	600	8	100



Table 8-2: Valve cylinder head to cylinder (socket head screws) torque specifications

NPS	Class	Socket head screw size	Torque (ft-lb)
2	150	1/4"-20	5
2	300	1/4"-20	5
2	600	1/4"-20	5
3	150	1/4"-20	5
3	300	1/4"-20	5
3	600	1/4"-20	5
4	150	1/4"-20	5
4	300	1/4"-20	5
4	600	1/4"-20	5

## 8.4.2 Standard cylinder reassembly

### Reassembly of a 707 control valve

#### Procedure

1. Place the cylinder in an upright position with the ports on the bottom. Lubricate the inside of the cylinder wall with a suitable lubricant.
2. Insert the O-ring into the groove inside the bottom of the cylinder. This will require some effort.
3. Insert the seat ring into the cylinder; placing it on top of the O-ring.
4. Using the piston as your tool, place it nose end down into the cylinder on top of the seat ring. Using a hammer handle or similar device, press down on the piston to force the seat ring into position against the lip in the cylinder.
5. Remove the piston from the cylinder.
6. With the piston in a vertical position, nose end down, place the O-ring into the groove on the piston. (If the valve is a high-pressure model, the piston will require PTFE backup rings on either side of the O-ring).
7. Insert the piston into the cylinder, nose end down.
8. Turn the jack-out screws in the cylinder head to their original position.
9. Place the O-ring into the groove in the cylinder head.
10. Place the cylinder head on top of the spring.



#### **CAUTION**

##### **SPRING PRESSURE HAZARD**

Follow the instructions in Step 10.

Failure to comply may cause force to release the spring, resulting in serious injury or equipment damage.

11. Align the holes in the cylinder head with the mating holes in the cylinder and insert the screws into the holes in the cylinder head. Tighten the screws using an Allen wrench.
12. Place the O-rings into the grooves in the outside of the cylinder.
13. Insert the spring into the piston, spring should extend above cylinder head.
14. Install O-ring and Backup ring onto spring plunger.
15. Insert spring plunger into spring cover.
16. Place spring guide on top of springs and install spring cover on top of spring and spring guide.
17. Use an arbor press on top of the spring cover to press the springs.
18. Align the holes in the cylinder head with the mating holes in the spring cover and insert the screws into the holes in the cylinder head. Tighten the screws using an Allen wrench.
19. Remove the cylinder assembly from the arbor press.
20. Reconnect tubing to center of the cylinder head.
21. Install adjustment screw and locking cap.

## 8.5 Planned maintenance tasks

Table 8-3: Planned maintenance tasks

Task	Recommended action
Inspect	Implement a periodic inspection program to ensure all parts are free from damage during its use due to process, ambient or other abnormal conditions. <ul style="list-style-type: none"> <li>• Internal components: cylinder, piston, spring, cylinder head, seat retainer</li> <li>• Control valve body</li> <li>• Bolting</li> </ul>
Clean	Use a non-toxic metal cleaning solvent. Do not use common petrochemical solvents like Benzene, Toluene or Xylene as they can pose potential health hazards.
Monitor corrosion / erosion / wear	A careful review of the control valve proving history, such as control valve factor control charts, can reveal potential problems bearing drag due to wear or increased internal cross-sectional area due to erosion.
Part (seal) replacement	Visual inspection of the O-rings is recommended once a year and replacement of the O-rings is recommended at least once every five years. Follow internal procedures for part replacement. Do not twist or overstretch the O-ring during assembly.

**Table 8-3: Planned maintenance tasks (continued)**

<b>Task</b>	<b>Recommended action</b>
Corrosion monitoring	Daniel recommends visually inspecting the control valve for corrosion in the internal components at least once a year. Follow internal procedures for corrosion. The valve was designed without corrosion allowance. Periodically inspect the valve's metal parts for corrosion and erosion, and inspect the seals and O-rings for wear and chemical damage.
Lubricant information	High-viscosity silicone oil with a temperature range of -54° C to 204° C (-65° F to 400° F).
Proper lubrication procedure	Lubricate the entire surface of the O-ring before installation with a thin layer of high-viscosity silicone oil. Remove excess lubricant.

## 9 Corrective maintenance

### 9.1 Control valve troubleshooting

Use the table below to troubleshoot the control valve. Contact the nearest Flow Lifecycle Services center for assistance with repairs of Daniel products. It is important that servicing be performed by trained and qualified service personnel.

**Table 9-1: Troubleshooting issues of 707 Backpressure Control Valve**

Condition	Probable cause	Correction (1)
Valve will not open	Upstream valve is closed	Open upstream valve.
	Pump is not operating	Start pump and check for cavitation.
	Downstream valve is closed	Open downstream valve. (Check coupler on bottom loading units and internal valve in truck.)
	Insufficient pressure	Check pump. Check bypass and strainer located in line.
	Swollen O-rings	Disassemble valve and replace O-rings. Check compatibility of O-rings with product.
Valve opens too slowly	Swollen O-rings	Disassemble valve and replace O-rings. Check compatibility of O-rings with product.
Valve will not close off tightly	Foreign material in main valve piston seat	Disassemble valve and inspect piston.
	Swollen O-rings	Disassemble valve and replace O-rings. Check compatibility of O-rings with product.
	Piston or seat O-ring cut or defective	Disassemble valve and replace if necessary.

(1) Refer to Mechanical disassembly procedures.

### 9.2 Verify the return to operational condition

Once corrective maintenance has taken place, verify that the control valve is working properly by following the steps below.

**Procedure**

1. Inspect all bolts used to secure the control valve in-line to ensure that proper mounting procedures have been followed and that flange connections are leak-free.
2. Evaluate the system setup to ensure that all components are in the correct operating sequence.

3. Evaluate the system setup to ensure that all components are in the correct sequence for accurate product measurement. Some components are isolation valves, strainers, flow straighteners, turbine meters, downstream sections, etc.

# 10 Spare parts

## 10.1 Recommended spare parts

**Table 10-1: Recommended spare parts**

NPS	Class	Viton® O-Ring kit
2	150-300	W520155-692
	600	W526160-692
3	150-300	W530155-692
	600	W536160-692
4	150-300	W540155-692
	600	W546160-692

### Order spare parts

Contact Flow Lifecycle Services for Daniel products and provide the following information when ordering parts:

- Daniel control valve serial number
- Part number
- Part description
- Quantity

# 11 Decommission

## 11.1 Shut down the control valve

Follow the steps below to shut down and disassemble the control valve for storage or shipment.

 **WARNING**

**PRESSURE HAZARD**

The control valve is subject to pressurized fluids. Isolate the control valve upstream and downstream.

Always depressurize the control valve before disassembly.

Failure to comply may cause high pressure fluids to leak, resulting in death or serious injury.

**Procedure**

1. Ensure that the valve is free of contaminants.
2. Drain the valve of liquids.
3. Clean the valve components.
4. Label all parts or place parts in labeled containers during disassembly.
5. Do not use metal clamping devices in direct contact with control valve parts or surfaces.

## 11.2 Shipment of the control valve

Refer to Flow Lifecycle Services for Daniel products information in the preface of this document.

With over 90 years of experience, Daniel is the only manufacturer that has the knowledge and experience to engineer and offer superior products that are trusted to provide the most reliable and accurate measurements in the global oil and gas industry.

**Contact Us**

Email: [Sales@Daniel.com](mailto:Sales@Daniel.com)  
Phone: +1 (346)-509-3700



[www.Daniel.com](http://www.Daniel.com)