

DANIEL[®]

SENIOR ORIFICE FITTING

BILL OF MATERIALS

VALVE CARRIER AND STRIP KIT

DMC-20079587

DAN-20080015

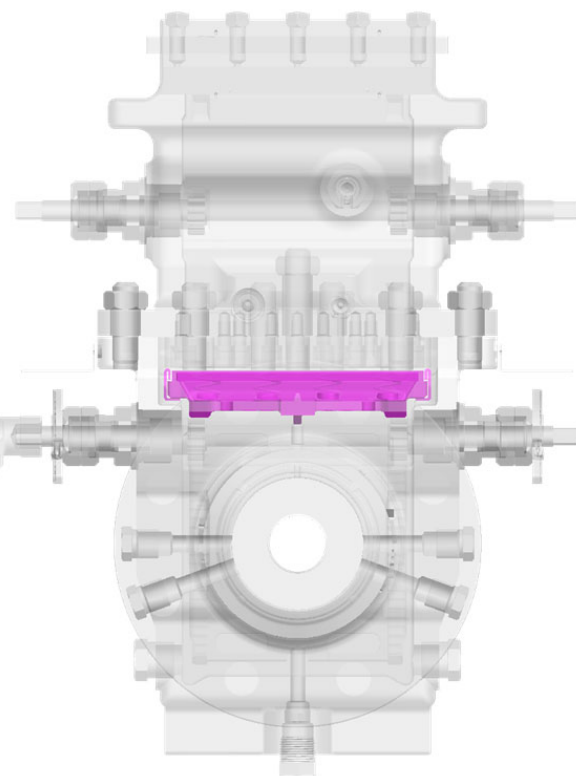
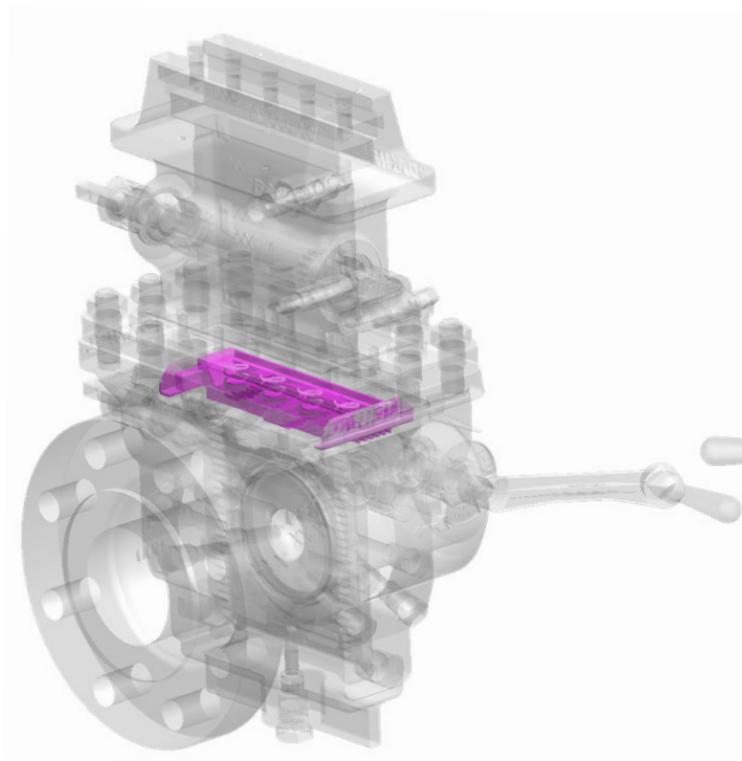

DANIEL[®]

KIT NUMBER: DAN-20072572

SLIDE VALVE CARRIER AND STRIP KIT 2" 150-600 NACE TRIM (MANUFACTURED 1992-PRESENT)

Part No.	Item No.	Description	Quantity
1-301-12-012	#3	SLIDE VALVE STRIP)	1
1-504-01-037	#15	SLIDE VALVE SPRING	4
1-301-19-061	#16	SLIDE VALVE CARRIER GUIDE, LEFT HAND / RIGHT HAND	2
1-504-01-561	#17 ¹	SLIDE VALVE CARRIER	1

¹ Valve carriers may need additional modifications (grinding and/or filling) in order to account for assembly variation

KIT NUMBER: DAN-20072603**SLIDE VALVE CARRIER AND STRIP KIT 3" 150-600 NACE TRIM (MANUFACTURED 1992-PRESENT)**

Part No.	Item No.	Description	Quantity
1-301-12-018	#3	SLIDE VALVE STRIP	1
1-504-01-037	#15	SLIDE VALVE SPRING	5
1-301-19-061	#16	SLIDE VALVE CARRIER GUIDE, LEFT HAND / RIGHT HAND	2
1-504-01-565	#17 ¹	SLIDE VALVE CARRIER	1

¹ Valve carriers may need additional modifications (grinding and/or filling) in order to account for assembly variation

KIT NUMBER: DAN-20072604

SLIDE VALVE CARRIER AND STRIP KIT 4" 150-600 NACE TRIM (MANUFACTURED 1992-PRESENT)

Part No.	Item No.	Description	Quantity
1-301-12-028	#3	SLIDE VALVE STRIP	1
1-504-01-037	#15	SLIDE VALVE SPRING	4
1-301-19-061	#16	SLIDE VALVE CARRIER GUIDE, LEFT HAND / RIGHT HAND	2
1-504-01-568	#17 ¹	SLIDE VALVE CARRIER	1

¹ Valve carriers may need additional modifications (grinding and/or filling) in order to account for assembly variation

KIT NUMBER: DAN-20072606**SLIDE VALVE CARRIER AND STRIP KIT 6" 150-600 NACE TRIM (MANUFACTURED 1992-PRESENT)**

Part No.	Item No.	Description	Quantity
1-301-12-038	#3	SLIDE VALVE STRIP	1
1-504-01-037	#15	SLIDE VALVE SPRING	6
1-301-19-061	#16	SLIDE VALVE CARRIER GUIDE, LEFT HAND / RIGHT HAND	2
1-504-01-570	#17 ¹	SLIDE VALVE CARRIER	1

¹ Valve carriers may need additional modifications (grinding and/or filling) in order to account for assembly variation

KIT NUMBER: DAN-20072607

SLIDE VALVE CARRIER AND STRIP KIT 8" 150-600 NACE TRIM (MANUFACTURED 1992-PRESENT)

Part No.	Item No.	Description	Quantity
1-301-12-050	#3	SLIDE VALVE STRIP	1
1-504-01-037	#15	SLIDE VALVE SPRING	10
1-301-19-061	#16	SLIDE VALVE CARRIER GUIDE, LEFT HAND / RIGHT HAND	2
1-301-12-137	#17 ¹	SLIDE VALVE CARRIER	1

¹ Valve carriers may need additional modifications (grinding and/or filling) in order to account for assembly variation

KIT NUMBER: DAN-20072608**SLIDE VALVE CARRIER AND STRIP KIT 10" 150-600 NACE TRIM (MANUFACTURED 1992-PRESENT)**

Part No.	Item No.	Description	Quantity
1-301-12-056	#3	SLIDE VALVE STRIP	1
1-504-01-037	#15	SLIDE VALVE SPRING	12
1-301-19-061	#16	SLIDE VALVE CARRIER GUIDE, LEFT HAND / RIGHT HAND	2
1-301-12-141	#17 ¹	SLIDE VALVE CARRIER	1

¹ Valve carriers may need additional modifications (grinding and/or filling) in order to account for assembly variation

KIT NUMBER: DAN-20072612

SLIDE VALVE CARRIER AND STRIP KIT 12" 150-600 NACE TRIM (MANUFACTURED 1992-PRESENT)

Part No.	Item No.	Description	Quantity
1-301-12-062	#3	SLIDE VALVE STRIP	1
1-504-01-037	#15	SLIDE VALVE SPRING	13
1-301-19-061	#16	SLIDE VALVE CARRIER GUIDE, LEFT HAND / RIGHT HAND	2
1-301-12-145	#17 ¹	SLIDE VALVE CARRIER	1

¹ Valve carriers may need additional modifications (grinding and/or filling) in order to account for assembly variation

Daniel™ Senior® Orifice Fitting

The standard in natural gas flow measurement

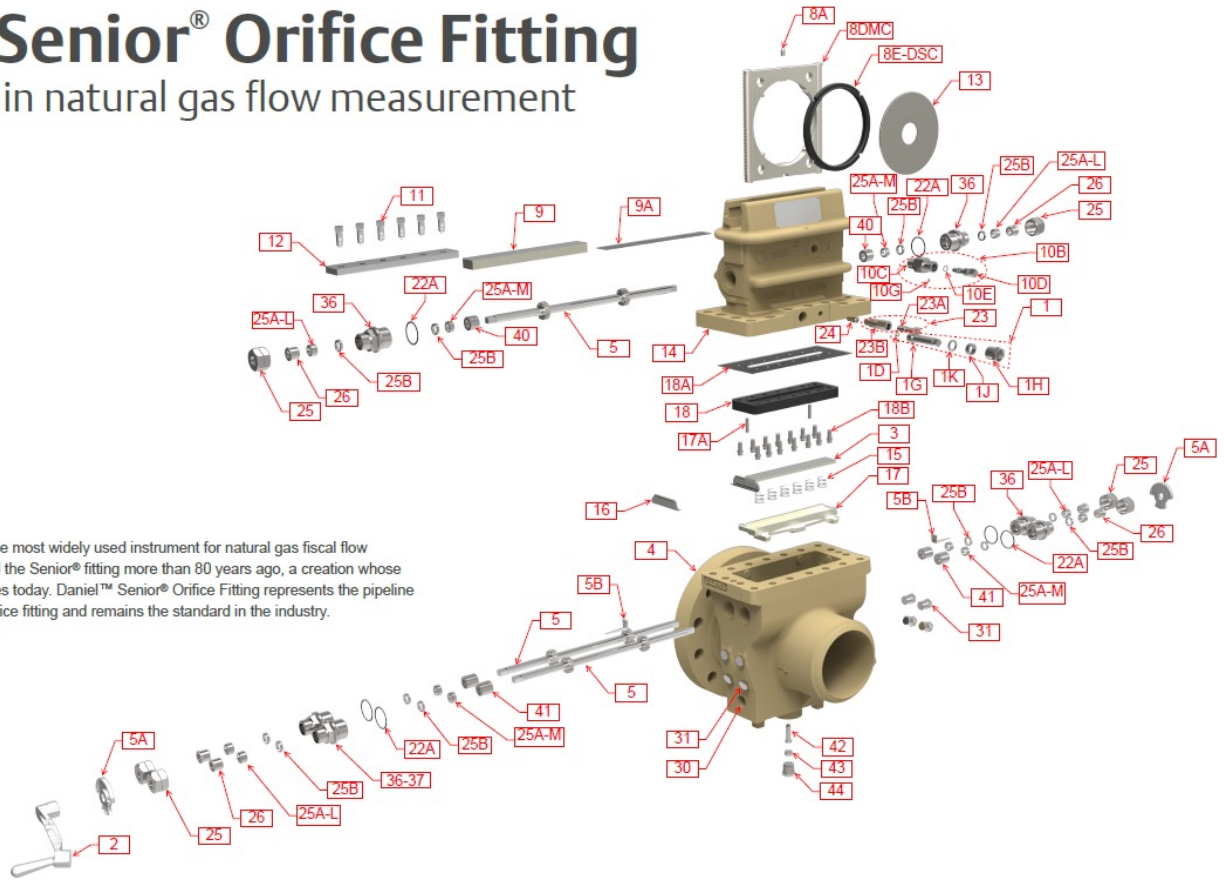

Daniel™ Senior® Orifice Fitting is the most widely used instrument for natural gas fiscal flow measurement. Paul Daniel invented the Senior® fitting more than 80 years ago, a creation whose fundamental design concept endures today. Daniel™ Senior® Orifice Fitting represents the pipeline industry's leading dual-chamber orifice fitting and remains the standard in the industry.

Item Number	Description
#1	Equalizer Valve, Complete
#1D	Equalizer Valve, Ball
#1G	Equalizer Valve, Stem
#1H	Equalizer Valve, Packing Nut
#1J	Equalizer Valve, Packing Ring
#1K	Equalizer Valve, Packing Washer
#2	Operating Wrench
#3	Slide Valve Strip
#5A	Indicator Plate LH/RH
#5B	Indicator Pointer
#5	Gear Shaft
#9	Sealing Bar
#9A	Sealing Bar Gasket
#10B	Bleeder Valve, Complete
#10C	Bleeder Valve, Body
#10D	Bleeder Valve, Needle
#10E	Bleeder Valve, O-ring
#10G	Bleeder Valve, Set Screw
#11	Clamping Bar Screw
#12	Clamping Bar
#15	Slide Valve Spring
#16	Slide Valve Carrier Guide LH/RH

#17	Slide Valve Carrier
#17A	Slide Valve Carrier Seat Pin
#18	Slide Valve Seat
#18A	Slide Valve Seat Top Gasket
#18B	Slide Valve Seat Screw
#22A	Bearing Plug/Stuffing Box Gasket
#23	Grease Gun, Complete
#24	Double Ball Check Valve
#25	Packing Nut
#25A-L	Packing Ring
#25A-M	Packing Ring
#25B	Centering Ring
#26	Stuffing Box Gland
#30	Drain Plugs
#31	Meter Tap Plugs
#36-37	Stuffing Box Body
#40	Stuffing Box Sleeve, Top
#41	Stuffing Box Sleeve, Body
#42	Plate Carrier Stop Pin
#43	Stop Pin Lock Screw
#44	Stop Pin Access Plug

With over 90 years of experience, Daniel is the only manufacturer that has the knowledge and experience to engineer and offer superior products that are trusted to provide the most reliable and accurate measurements in the global oil and gas industry.

Contact Us

Email: Sales@Daniel.com
Phone: +1 (346)-509-3700



www.Daniel.com