

DANIEL®

LIQUID CONTROL VALVES

PRODUCT GUIDE

710 | 711 | 750 | 754 | 760 | 761 | 770

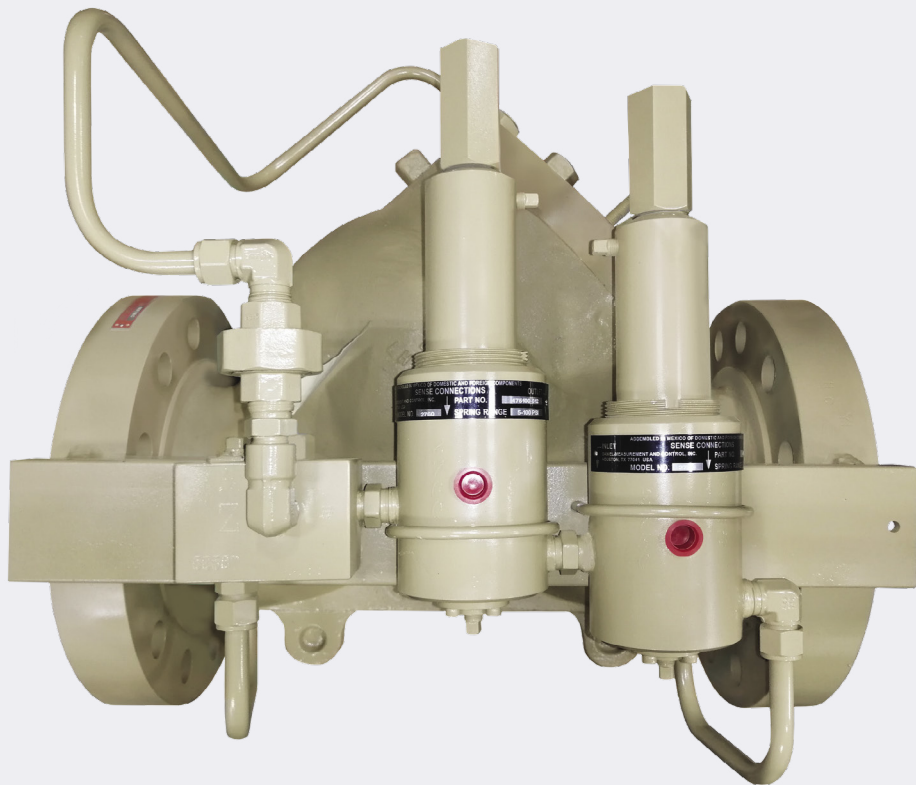

DANIEL®

Decades Proven. Field Chosen.™

DANIEL™ 700 SERIES PILOT OPERATED CONTROL VALVES

Precise Flow Control of Petroleum Products

Whether your application is pipeline control or blending, flow rate or pump control, Daniel has the control valve you need.

All Daniel 700 Series control valves are self-contained and externally pilot-operated, so one basic valve can perform many different functions. Multiple pilot arrangements, easily modified, allow you to choose or change valve capability as required.

Unique design features and unit-built construction assures positive sealing, linear valve action, uniform fast response and leak-proof performance. In addition, the basic valves body and internals are the same throughout the line, simplifying spare parts inventory and reducing costs.

Each 700 Series model is designed for general control applications using an external pilot for multiple control functions. These valves can be installed in a horizontal or a vertical line with flow direction vertical up.

Features and Benefits

- Balanced piston principle, spring biased
- Adjustable closing speed control prevents damage to shock pressures
- Linear valve action - rectangular ports provide smooth linear action with maximum flow and minimum pressure drop
- Uniform speed of response - uniform area above main piston provides uniform opening and closing speed with fast rate of response
- Positive (pressure type sealing) O-ring seal and valve seats are not affected by fluid viscosity or pressure drop
- High capacity 45° (in-line) valve body assures high capacity at low pressure drop
- Sensitive regulation - pressure from 10 to 1440 psi (69 - 9928 kPa) can be controlled within ± 2 psi of set point (± 13.8 kPa)
- Large internal pilot valve ports
- Zero leakage - contoured edge of piston provides a tight seal and assures drip-tight operation and dead-end service
- Unit-built construction - all internal parts, including seat ring, can be removed as a unit without disturbing valve body and connections
- Simple design - no diaphragms or stuffing boxes
- Inherent design of valve makes it an automatic check valve - no reverse flow



MODEL 710 / 711 ON - OFF SOLENOID OPERATED CONTROL VALVES

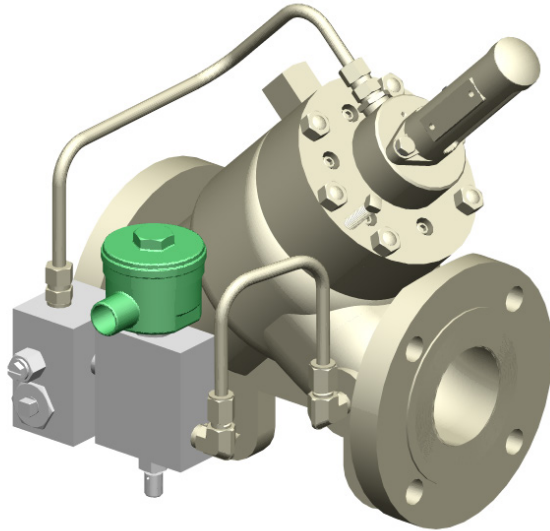

Typical Installation

The Model 710 valves are typically used to stop flow on applications such as high level shut-off into storage, on-off line block control, jet fuel filter-separator control from a water detector, blend line selection and many other applications requiring remote on-off control. The Model 710 closes upon loss of electrical power while the Model 711 opens upon loss of electrical power.

The Model 710, (normally closed), and Model 711, (normally open), solenoid operated control valves are designed for remote on-off control of flow. They are externally piped with a needle valve (speed of response control) and a strainer as standard equipment. Manual override is a standard feature of the Model 710.

Applications

- Batch control
- High level shut-off
- Filter separation water slug
- Remote on-off blend selection

Table 1: Solenoid Electrical Data		
Voltage*	Current (inrush)	Current (holding)
110 / 50 AC 120 / 60 AC	0.7 AMPS	0.33 AMPS
220 / 50 AC 240 / 50 AC	0.35 AMPS	0.17 AMPS

*DC Voltage and 440 / 480 available on request.

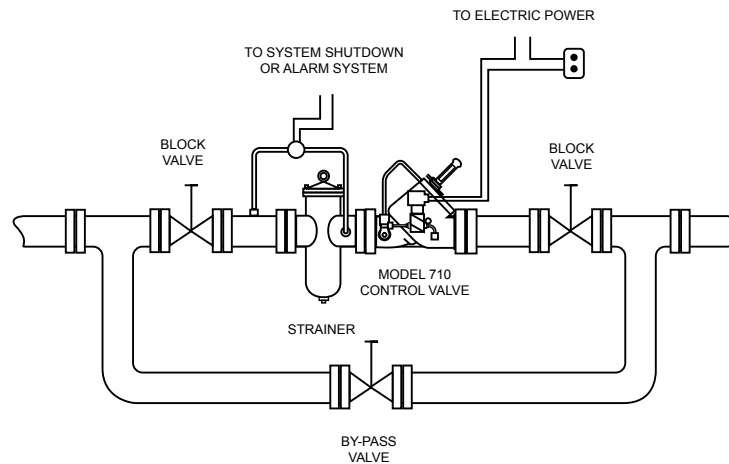
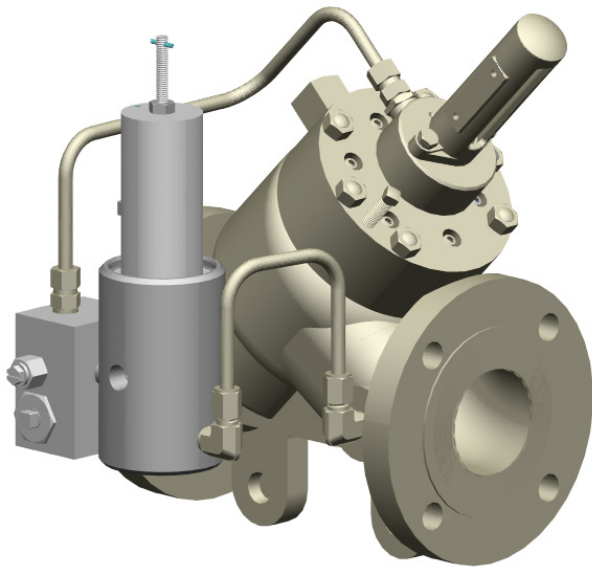

Figure 1: Remote On-Off and a strainer for high differential shut-down alarm or alarm system.

MODEL 750 PRESSURE REDUCING CONTROL VALVES



Typical Installation

The Model 750 pressure reducing valve is designed to regulate downstream pressure within ± 2 psi (13.8 kPa) or better, regardless of variations in flow rate or upstream pressure. The pilots are balanced, single seated valves with large ports and are not affected by variations in upstream pressure.

Applications

- Distribution system
- Meter over-pressurization protection
- Pipeline delivery to storage
- Pump suction pressure control (positive NPSH)

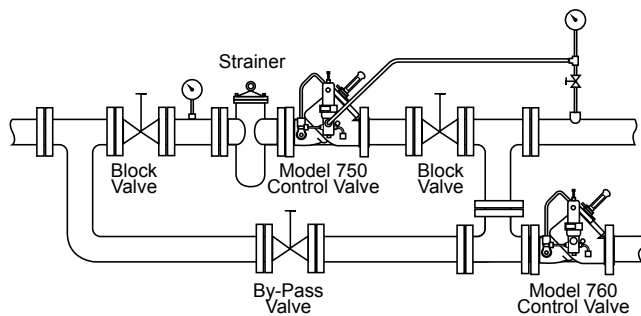

Figure 2 - This drawing illustrates the most common usage of the pressure reducing control valve. The Model 750 externally sensed to any point downstream, provides a sensitive control for regulation of pressure within ± 2 psi (13.8 kPa). The Model 760 back pressure control valve, acting as a relief valve, protects the system if excessive pressure or surge occurs.

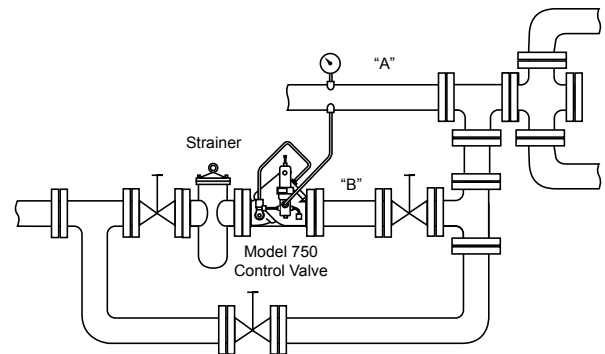

Figure 3 - Pipeline "A" normally provides all the product for distribution unless pressure drops below a required minimum. When this occurs the Model 750 installed in an auxiliary line "B" and sensed to the main line "A", opens to maintain pressure and flow until normal main line pressure is restored.

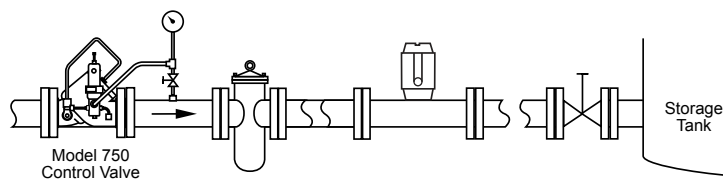
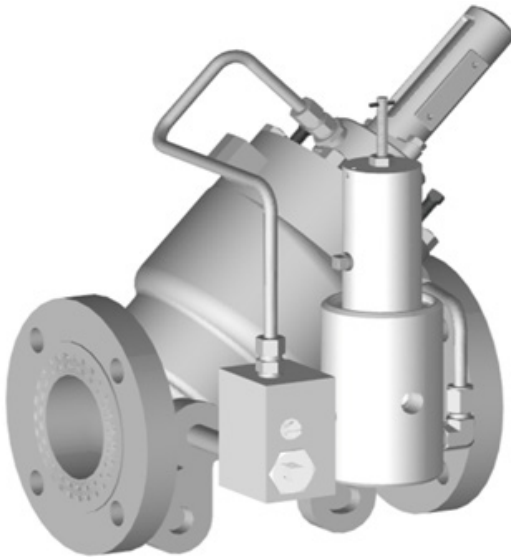

Figure 4 - In this application, the Model 750 pressure reducing valve lowers main pipeline pressure to a level that is within the acceptable rating of the metering equipment. The pressure reducing valve will control a maximum reduced pressure drop of 1,000 psi = 6,895 kPa.

MODEL 754 RATE OF FLOW CONTROL VALVES



Typical Installation

The Model 754 rate of flow control (flow limiting) valve is designed to maintain a controlled flow rate within $\pm 2\%$. The pilot is a balanced, single seated valve with large ports and will operate on a differential as low as 5 psi (34.5 kPa).

Applications

- To control flow rate when accurate, dependable flow control is required
- For limiting the maximum permissible flow through meters, pumps, process streams strainers, and filters

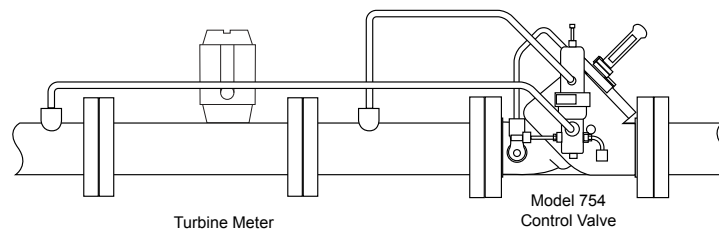
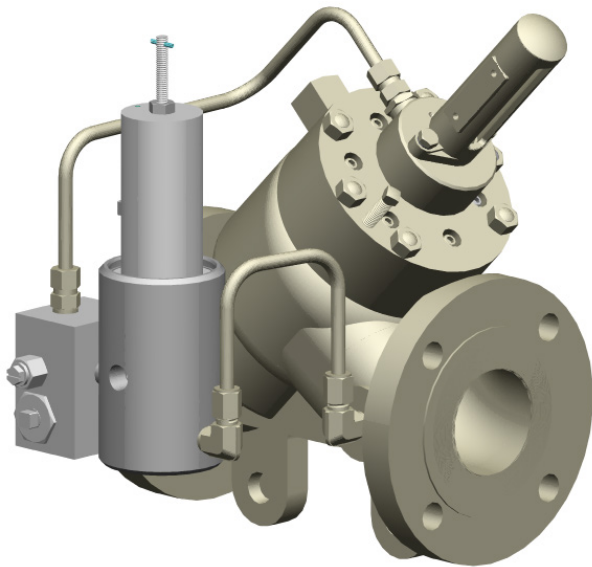

Figure 5 - Model 754 with turbine meter

MODEL 760 BACK PRESSURE / 761 PRESSURE RELIEF CONTROL VALVES



Typical Installation

The Model 760 and 761 control valves are designed to regulate valve inlet pressure within ± 2 psi (13.8 kPa) regardless of variations in flow rate or downstream pressure. The pilots are balanced, single seated valves with large ports and are not affected by variations in downstream pressure.

Applications

- Metering systems back pressure
- Pipelines (surge control)
- Pump bypass or pressure relief

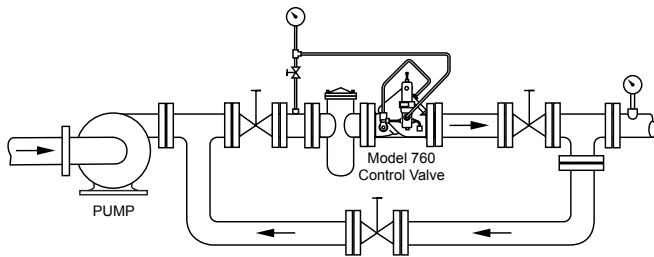

Figure 6 - The Model 760 is used to maintain constant pressure at the pump discharge. The valve opens when a predetermined pressure is reached, allowing flow to start, then it regulates back pressure on the pump within ± 2 psi. (13.8 kPa).

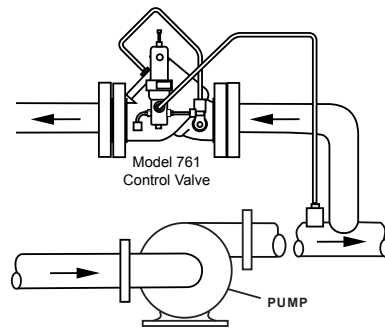

Figure 7 - The Model 761 illustrated here is applied either as a relief valve to protect the line against excessive pressure and surge or as a pump bypass valve to maintain a constant pump discharge. Flow through the valve may be piped to storage, pump suction, sump, or atmosphere.

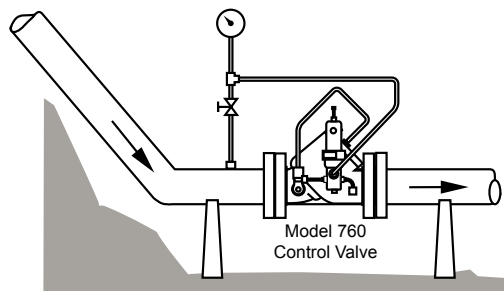
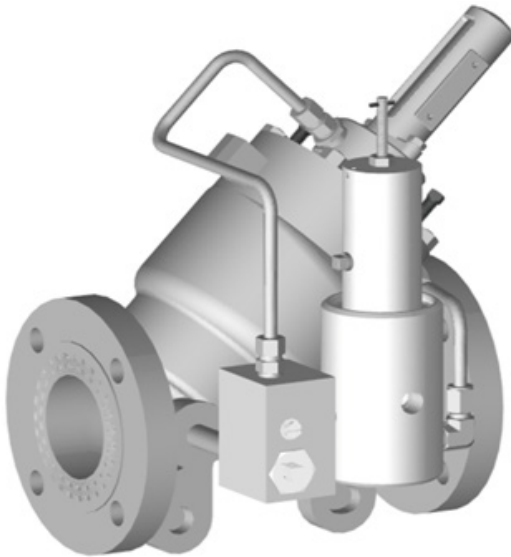

Figure 8 - The Model 760 installed in a pipeline at the bottom of an incline. The valve maintains a back pressure equal to head pressure and prevents liquid separation.

MODEL 770 DIFFERENTIAL CONTROL VALVES



Typical Installation

The Model 770 (normally closed) differential control valve is designed to maintain a controlled pressure differential within $\pm 2\%$ regardless of variations in upstream or downstream pressure. The pilots are balanced, single seated with large ports and operate on a differential as low as 5 psi (34.5 kPa).

Applications

- Maintains system pressure at a predetermined level above product pressure
- Vapor pressure control on LPG, NH₃ and similar products
- Pump differential pressure control
- Provides constant pump discharge flow rate by controlling differential pressure across an orifice plate

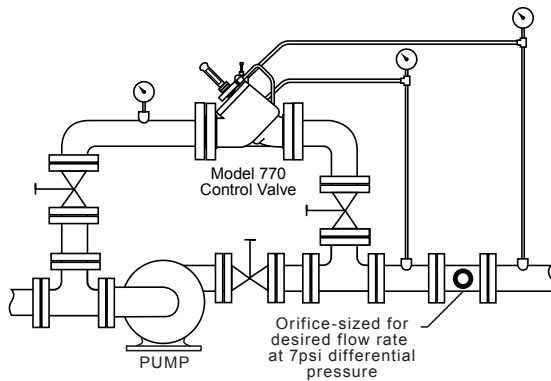

Figure 9 - The Model 770 control valve bypasses rate of flow control.

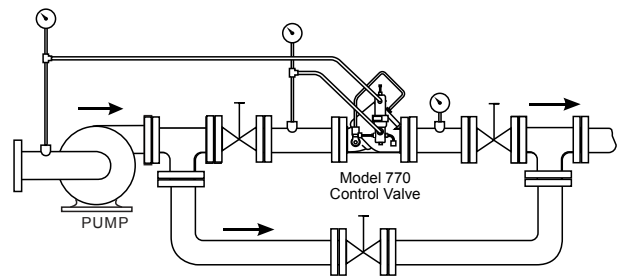

Figure 10 - The Model 770 controls differential pressure (LPG, NH₃).

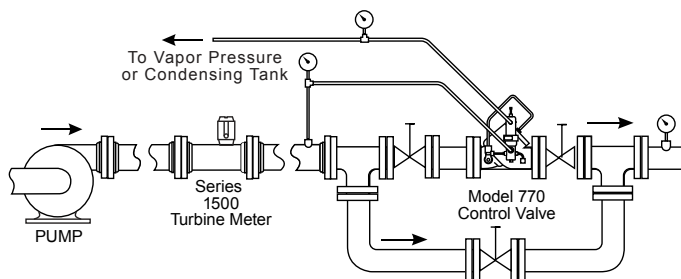

Figure 11 - The Model 770 control valve maintains minimum pump differential.

STANDARD SPECIFICATIONS

Please consult a Daniel technical specialist if requirements are outside of the listed specifications. Other product and material offerings may be available depending on the application.

Process Parameter

Temperature Range¹:

- 20°F to 150°F (-29°C to 66°C)
- Optional 400°F (204°C) (not available for solenoid operated valves)

Table 3: Pilot Spring Ranges

150 - 300 ANSI Valves		600 ANSI Valves	
(PSI)	(KPA)	(PSI)	(KPA)
0-20	0-138	5-100	34.5-990
*0-40	0-276	50-250	345-1724
30-80	207-552	200-400	1,379-2,758
70-180	483-1,241	350-650	2,413-4,482
150-350	1,034-2,413	600-950	4,137-6,550
350-650	2,413-4,482	900-1,500	6,205-10,342

*Spring selection based on control pressure set point

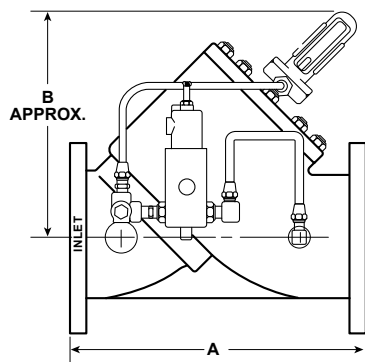

Table 2: Flange Connections / Ratings (DIN)

Valve Size	DIN PN16 MWP at 120°C	DIN PN25 MWP at 120°C	DIN PN40 MWP at 120°C	DIN PN64 (300 ANSI) MWP at 120°C	DIN PN64 (600 ANSI) MWP at 120°C	DIN PN100 MWP at 120°C
DN50-DN400	16 BAR	25 BAR	40 BAR	51 BAR	64 BAR	100 BAR

MWP: Maximum Working Pressure

Table 4: Flange Connections / Ratings (ANSI)

Valve Size	150 ANSI MWP at 100°F	300 ANSI MWP at 100°F	600 ANSI MWP at 100°F
2" - 16"	285 PSI	740 PSI	1,480 PSI

MWP: Maximum Working Pressure

Table 5: Valve Capacity

Valve Size	2"	3"	4"	6"	8"	10"	12"	16"
C _v (GPM)	86	186	309	688	1,296	2,040	2,920	5,360

Table 6: Flange Connections / Ratings (DIN)

Valve Size	150 LBS		300 LBS		600 LBS		150-300 LBS		600 LBS	
	Inches	MM	Inches	MM	Inches	MM	Inches	MM	Inches	MM
2"	10 1/4	260	10 1/2	267	11 1/2	292	10 7/8	276	10 7/8	276
3"	11	279	13 1/8	333	14	356	10 7/8	276	11 1/4	286
4"	13	330	14 1/2	368	17	432	10 7/8	276	11 1/2	292
6"	17	432	17 7/8	454	22	559	13 5/8	340	13 5/8	346
8"	22 1/4	565	23 1/4	591	26	660	17 1/4	438	17 3/4	451
10"	26 1/2	673	27 7/8	708	31	787	17 5/8	448	20 5/8	524
12"	30 7/8	784	33 5/8	854	36 1/2	927	22 7/8	581	22 7/8	581
16"	41 3/8	1,051	43 1/2	1,105	46	1,168	30	762	30	762

Materials of Construction

Main Valve Body

- Steel - ASTM-A352-GR-LCC

Main Valve Cylinder

- 2" - 4" Stainless Steel on 150 - 600 ANSI
- 6" - 16" Steel, Nickel Coated on 150 - 600 ANSI

Main Valve Piston

- Stainless Steel standard

Seat Ring

- 2" - 6" Stainless Steel
- 8" - 16" Steel, Nickel Coated
- Stainless Steel on 600 ANSI

O-Rings

- Standard - Viton
- Optional - Other O-Rings are available: Neoprene, EPR, all Viton , all Buna-N, Kalrez / Teflon AP (Aggress Products)
- Other Internal Parts: Stainless Steel

Pilot Valve Strainer / Needle Valve Trim

- Stainless Steel

Tubing and Fittings

- Standard - Stainless Steel

Aggressive Products Option

The use of aggressive additives or oxygenates call for the use of the Aggressive Products (AP) option. The AP option valve cylinder incorporates cup-seals (Teflon® Bal Seals) and an O-ring made from appropriate materials for such challenging conditions. Materials for pilots such as low swell nitrile (main valve static O-rings) and Kalrez® or Teflon® are available.

Standard Equipment

- Pre-wired solenoids (optional for CE execution)
- Sensitivity / closing speed controls
- Strainer on pilot inlet
- Steel pilot bodies
- Stainless Steel tubing and fittings

Recommended Spare Parts

- O-rings

Hazardous Area Classifications

- UL and CSA Listed
- Class I - Group C & D
- Class II - Group E, F & G
- Explosion Proof NEMA Types 7C, 7D, 9E, 9F, 9G and Waterproof NEMA Type 4
- CE (ATEX, PED [or SEP] and EMR)
- ATEX II 2G/D Ex d IIC T6-T4

Table 7: Approximate Shipping Weight and Volume

Valve Size	150-300 ANSI				600 ANSI			
	Shipping Weights		Shipping Volume		Shipping Weights		Shipping Volume	
	lbs	kgs	Cubic Feet	Cubic Meters	lbs	kgs	Cubic Feet	Cubic Meters
2"	60	27	1.7	0.047	100	45	1.8	0.051
3"	105	48	2.4	0.067	150	68	2.5	0.071
4"	140	64	2.5	0.071	205	93	3.1	0.089
6"	250	114	4.9	0.137	400	181	6.1	0.172
8"	465	211	8.9	0.253	725	329	10.0	0.283
10"	700	318	12	0.342	1,170	561	15.1	0.428
12"	1,251	567	20.3	0.573	1,820	826	21.9	0.621
16"	CF	CF	CF	CF	CF	CF	CF	CF

Purchase Specifications

The 700 Series valves are hydraulically operated and pilot controlled using the flow stream as the operating medium.

The main valves are pressure balanced, single seated, piston operated with 45° body construction.

The pilot valves are pressure balanced, piston operated and single seated.

A manual flow control valve is included in the pilot supply line of the valve to provide an adjustable closing rate. The valve pilot supply line includes a strainer.

A major benefit of the valve design is that all internal parts, including cylinder, piston and seat ring are removable as a cartridge assembly which keeps your line connections intact.

Ordering Information

When ordering, please specify:

- Valve size
- Flange type
- Product, product viscosity, product specific gravity
- Minimum and maximum operating temperature
- Minimum and maximum flow rates
- Minimum, normal and maximum operating pressures
- Control functions to be performed
- O-ring material
- Control pilot materials
- Tubing material
- Main valve piston material
- Pilot spring range
- Pilot spring setting (psi or kPa)
- Voltage required (if applicable)

January 2022

With over 90 Years of experience, Daniel is the only manufacturer that has the knowledge and experience to engineer and offer superior products that are trusted to provide the most reliable and accurate measurements in the global oil and gas industry.

Contact Us

Email: info@daniel.com

Phone: 713-467-6000



Decades Proven. Field Chosen.™

www.daniel.com

©2022 Daniel Measurement and Control | All Rights Reserved | DAN-LIQ-CV-PG-0122